

**Physics 103**  
**Practice Final Exam**

1. Please attach the take-home problem, which you completed independently during the previous five days, to this exam, and also attach the grade assessment sheet given to you in class last Wednesday, as per the instructions on the take-home exam sheet.

2. A team of four Clydesdales pulls the Budweiser delivery sleigh along a picturesque path in a snowy New England forest. Naturally, these can supply as much as four horsepower to the effort. <sup>1</sup> At the very end of the journey, the team encounters a  $7^\circ$  incline, which continues for a distance of 3 km. The sleigh driver has only four minutes to complete the ascent, else he will fail to make his (root-beer) delivery on-time. The mass of the laden sleigh is 3000 kg. The coefficient of kinetic friction between the sleigh runners and the snow-covered path is  $\mu_K = .25$ , *i.e.*, one-fifth.

a) Draw a free body diagram illustrating the sleigh (modelled as a point mass) and all of the forces which act on the sleigh while it is ascending the hill.

b) What is the magnitude of the normal force exerted by the hill on the sleigh?

c) What magnitude of force must the horses supply to the sleigh in order to maintain a constant velocity?

d) If the horses supply the particular force computed in part (c), then what would be the total amount of work done by the horses during the ascent of the 2 km hill? How much work is done by friction?

e) The sleigh driver must complete the final three kilometers in less than four minutes. If he is to succeed, then what average power would be required? Can he possibly succeed? What is the minimum number of horses which could successfully complete this task?

---

<sup>1</sup>One horsepower is equivalent to 756 Watts.

3. A terrifying roller coaster begins with a motorized ascent to the top of a hill having height  $H=175$  m. At the very top of this hill the roller coaster car has a velocity zero. It is then gently nudged over the edge, and accelerates downward due to the force of gravity alone. After returning to ground height, the roller-coaster traverses a vertically-oriented loop, whose top is at a height of 100 m above the ground. The radius of curvature of the loop, at its top, is  $R=30$  m. The combined mass of the car and the one rider is 250 kg.

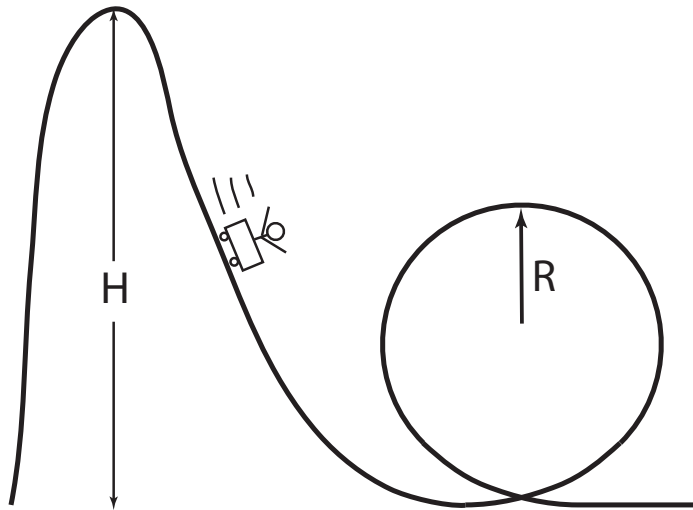

- Provided that friction is completely negligible, what is the velocity of the car when it is at the top of the loop?
- Draw a free body diagram of the car at the instant it is at the top of the loop.
- Using the result of part (a), determine the direction and the magnitude of the net force on the car when it is at the top of the loop. <sup>2</sup>
- Assume friction is not negligible. How much work would have to be done by friction between the time the car leaves the initial hill and the time it reaches the top of the loop, in order for a passenger to feel complete weightlessness?
- What would happen if the effect of friction were the same as determined in part (d) but if the passenger were 10 kg heavier? What if the passenger were 10 kg lighter?

---

<sup>2</sup>At the very instant the car is at the apex of the loop, the car experiences uniform circular motion.

4. The 4.00 kg block in the figure to the right is attached to a vertical rod by means of two strings. When the system rotates about the axis of the rod, the strings are extended as shown in the diagram and the tension in the upper string is 80.0 N.

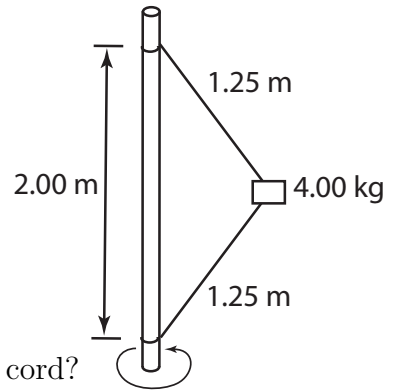

- What is the vertical component of the tension in the upper cord?
- What is the magnitude of the tension in the lower cord?
- How many revolutions per minute does the system make?
- If the block rotates instead at a lower rate of speed, the tension in each cord is reduced. Find the number of revolutions per minute at which the lower cord just goes slack.
- What happens if the number of revolutions per minute is less than that determined in part (c)?