

ROSES ARE RED AND VIOLETS ARE BLUE

(14 points) The pigment in hydrangea blossoms belongs to the class of molecules called anthocyanins, or, more particularly, it is a cyanidin. Cyanidins are responsible for the red color of roses, strawberries, raspberries, apple skins, rhubarb, and cherries and for the purple color of blueberries. What is more, the color of cyanidins depends on the pH. Red cabbage juice is only red in acid; it is purple in a more neutral solution.

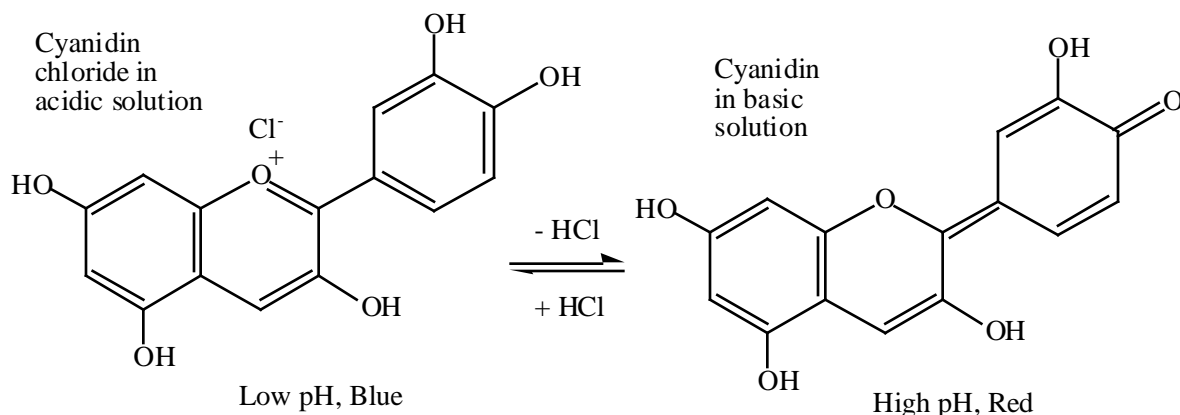

The reason for this shift in color with pH is that the pigment is an acid and can donate an H⁺ ion. As the pH increases, the conjugate base is formed, and this is accompanied by a significant color change. This means that the color is a reflection of the pH of the solution. If the pH could be controlled, then the color could be controlled. (See <http://antoine.fsu.umd.edu/chem/senese/101/features/water2wine.shtml>)

- The ideal range of pH for blue flowers is a pH of 5.5. This means that $[H_3O^+] =$ _____
- The ideal range of acidity to produce pink flowers is $[H_3O^+] = 4.0 \times 10^{-7}$ M. This means the pH must be about _____
- If you wanted to buffer a solution near a pH of 5.5, which system below would you choose?
 - A mixture of HCl and NaCl
 - A mixture of acetic acid and sodium acetate
 - A mixture of ammonia and ammonium chloride
- The cyanidins pictured above are soluble in water. Based on the structure of the molecule, explain briefly but completely why this should be so.

5. The blue form of cyanidin is illustrated below. Answer the questions regarding formal charge, atom hybridization, and geometry. *Note that lone pairs on the O atoms are not shown.*

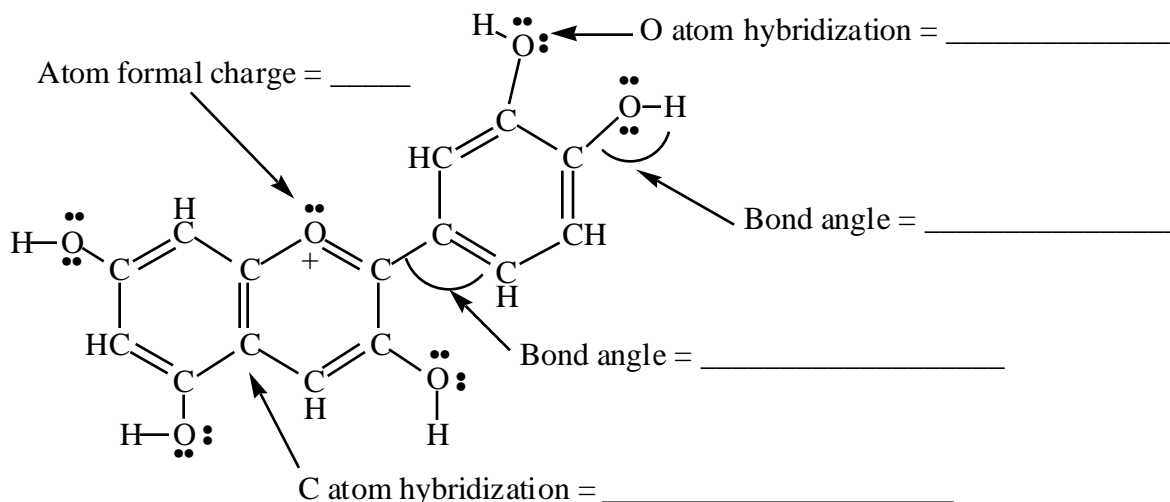

6. The blue form is stabilized by adding aluminum salts to the soil. If you add AlCl_3 to water, and it dissolves to produce $\text{Al}^{3+}(\text{aq})$ and $\text{Cl}^{-}(\text{aq})$ ions, is the solution acidic, basic, or neutral? _____

REDOX CHEMISTRY AND MOLECULAR STRUCTURE

(6 points) *Reaction of nicotinamide, an very important biochemical.*

- a) Is the reaction below an oxidation or reduction? _____
- c) Fill in the blanks on the figure.
- b) Describe what happens to the geometry and hybridization of the indicated C atom.

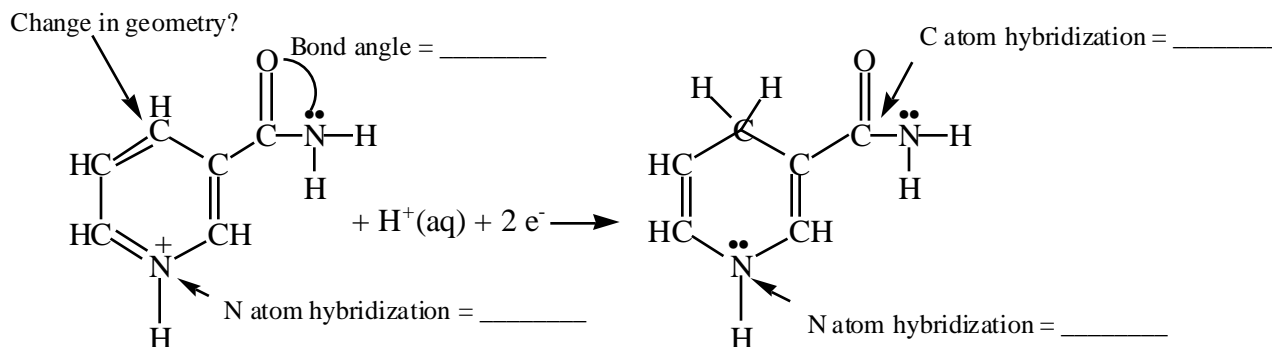

ELECTROCHEMISTRY

1. (6 points) Consider the electrochemical cell below.

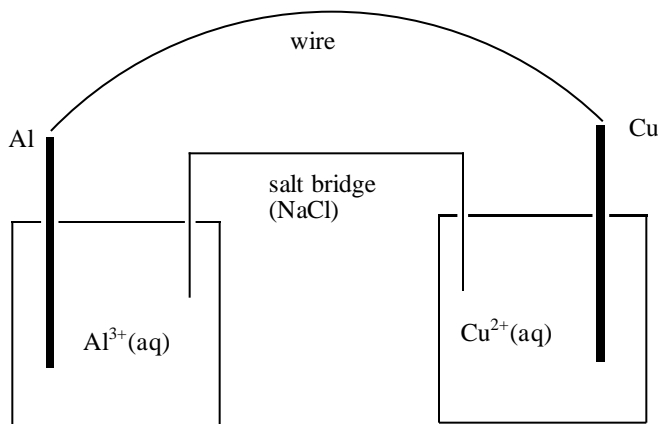

- a) Using Table 21.1 (page 970), decide which is the better reducing agent, Al or Cu? _____
- b) Which reaction occurs in this electrochemical cell?
- i) $2 \text{Al(s)} + 3 \text{Cu}^{2+}(\text{aq}) \rightarrow 2 \text{Al}^{3+}(\text{aq}) + 3 \text{Cu(s)}$
- ii) $2 \text{Al}^{3+}(\text{aq}) + 3 \text{Cu(s)} \rightarrow 2 \text{Al(s)} + 3 \text{Cu}^{2+}(\text{aq})$
- c) Which is the anode in the cell, Al or Cu? _____
- d) What is the standard cell potential? $E^\circ =$ _____
- e) Electrons flow in the external wire
- i) from Al to Cu
- ii) from Cu to Al
- f) Na^+ ions in the *salt bridge* flow
- i) from the Al^{3+} solution to the Cu^{2+} solution
- ii) from the Cu^{2+} solution to the Al^{3+} solution



2. (8 points) Consider the following reduction half-reactions:

<u>Half-Reaction</u>	<u>E°(V)</u>
$\text{Ce}^{4+}(\text{aq}) + \text{e}^{-} \rightarrow \text{Ce}^{3+}(\text{aq})$	+1.61
$\text{Ag}^{+}(\text{aq}) + \text{e}^{-} \rightarrow \text{Ag}(\text{s})$	+0.80
$\text{Hg}_2^{2+}(\text{aq}) + 2 \text{e}^{-} \rightarrow 2 \text{Hg}(\ell)$	+0.79
$\text{Sn}^{2+}(\text{aq}) + 2 \text{e}^{-} \rightarrow \text{Sn}(\text{s})$	-0.14
$\text{Ni}^{2+}(\text{aq}) + 2 \text{e}^{-} \rightarrow \text{Ni}(\text{s})$	-0.25
$\text{Al}^{3+}(\text{aq}) + 3 \text{e}^{-} \rightarrow \text{Al}(\text{s})$	-1.66

- (a) Which is the weakest oxidizing agent in the list? _____
- (b) Which is the strongest oxidizing agent? _____
- (c) Which is the strongest reducing agent? _____
- (d) Which is the weakest reducing agent? _____
- (e) Will Sn(s) reduce $\text{Ag}^{+}(\text{aq})$ to Ag(s)? _____
- (f) Will Hg(ℓ) reduce $\text{Sn}^{2+}(\text{aq})$ to Sn(s)? _____
- (g) Name the ions that can be reduced by Sn(s). _____
- (h) What metals can be oxidized by $\text{Sn}^{2+}(\text{aq})$? _____

Good luck!
—and thanks
for a good year!



Intermolecular Forces

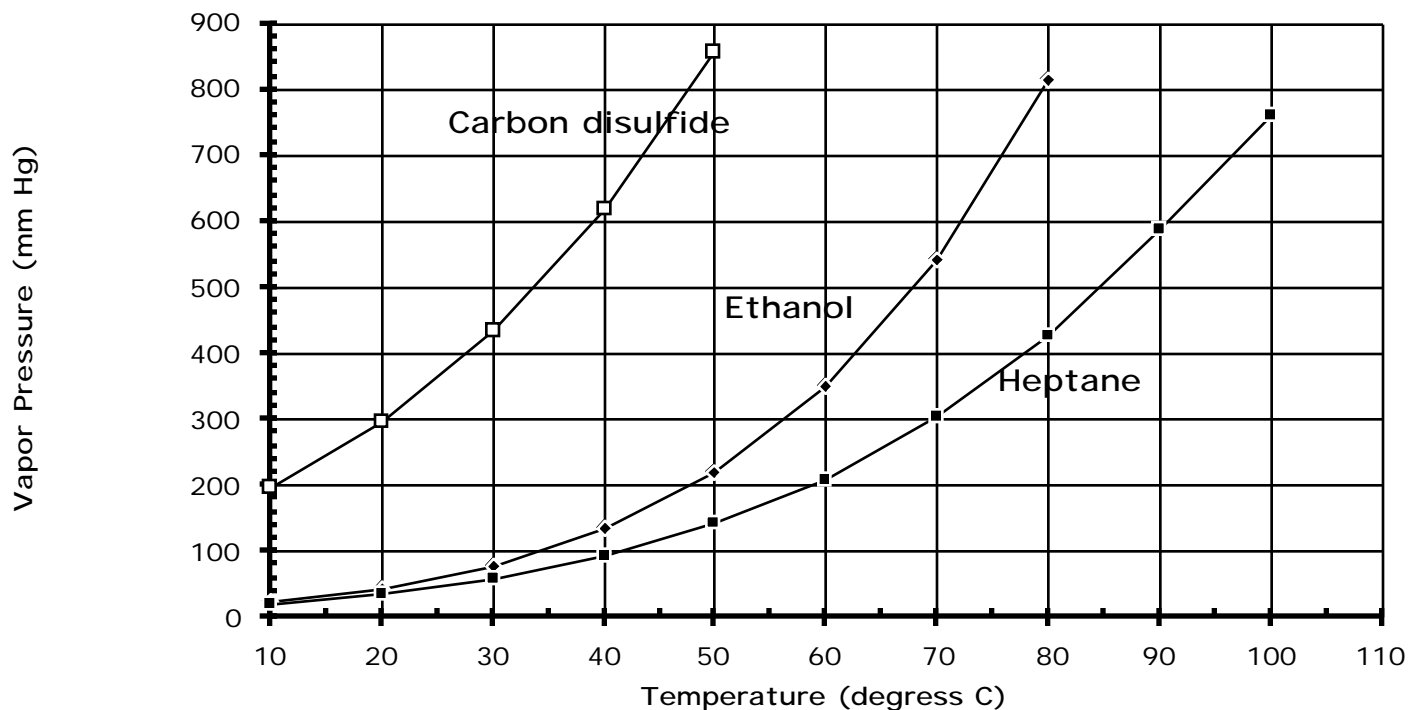

(13 points) Use the vapor pressure curves above to answer the following questions:

1. What is the vapor pressure of heptane at 70 °C? _____
2. What is the normal boiling point of ethanol? _____
3. What type of intermolecular force exists
 - a) between two CS_2 molecules? _____
 - b) between two heptane molecules? _____
 - c) between two ethanol molecules? _____
4. Suppose the pressure is 600 mm Hg and the temperature is 50 °C. Decide if each substance is a liquid or vapor under those conditions.
 - a) Carbon disulfide _____
 - b) Ethanol _____
 - c) Heptane _____
5. Which one or ones of these molecules is expected to dissolve in water?

6. Explain briefly why the normal boiling point of ethanol is higher than that of CS_2 .
7. Why is the normal boiling point of heptane higher than that of CS_2 ?

SOLIDS

1. (7 points) Silver iodide crystallizes in the unit cell shown here.

(a) How many silver ions are there in each unit cell?

(b) How many iodide ions are there in each unit cell?

(c) What is the solubility of silver iodide in water?

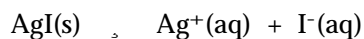

i) 1.5×10^{-16} mol/L

ii) 1.2×10^{-8} mol/L

iii) 2.4×10^{-8} mol/L

iv) 0.0012 mol/L

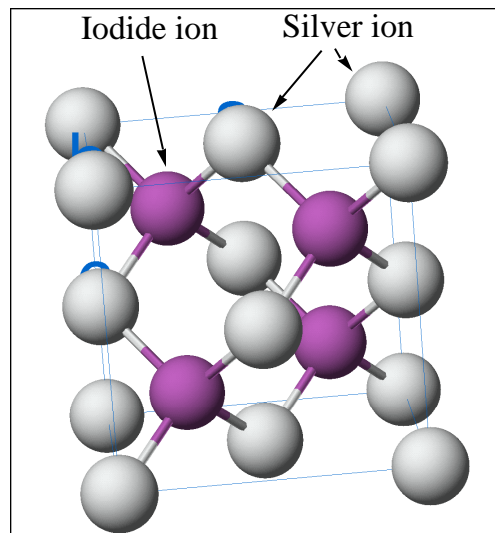

2. (4 points) Magnesium oxide, MgO, has a NaCl-like crystal structure.

(a) In which type of unit cell are the Mg^{2+} ions arranged (sc, bcc, fcc)? _____

(b) How many magnesium ions are there per unit cell?

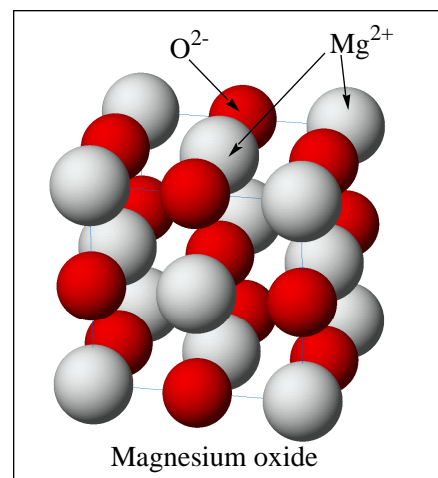

3. (8 points) Two views of the structure of rutile are shown here.

(a) How many titanium ions are inside the unit cell?

(b) How many oxide ions are inside the unit cell?

(c) What is the formula of rutile? _____

(d) What is the charge on the titanium ion in rutile? _____

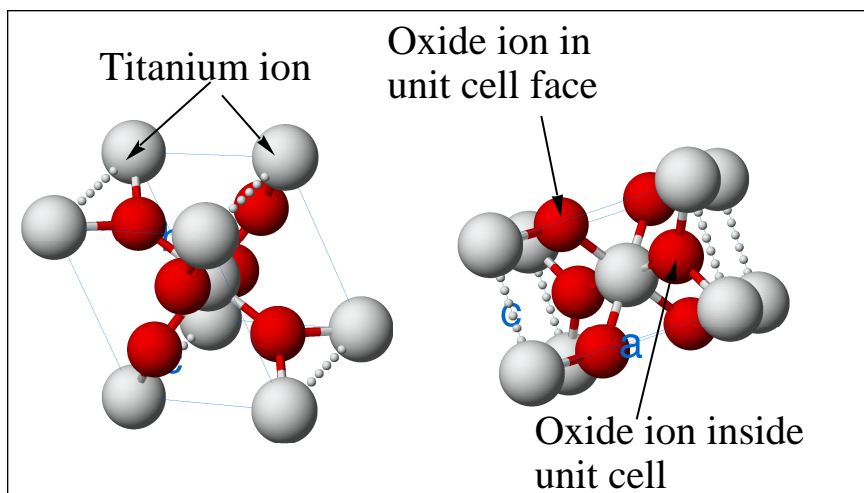

GASES

Teflon, a polymer composed of carbon and fluorine is widely used. Its manufacture requires very simple molecules such as HF and CHCl_3 . These produce CHClF_2 with hydrogen chloride as a byproduct.

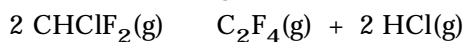

- (3 points) You have a 15.5 L tank containing 162 g of HCl gas at 25 °C. What is the pressure in the tank?
 - 0.36 atm
 - 0.59 atm
 - 7.0 atm
 - 260 atm
- (13 points) Draw electron dot structures for the molecules below.
 - CHClF_2 Number of valence electrons = _____

The electron pair geometry of the molecule is _____ and its molecular geometry is _____. The C atom hybridization is _____. The molecule is *(polar)(nonpolar)* _____.

- C_2F_4 Number of valence electrons = _____

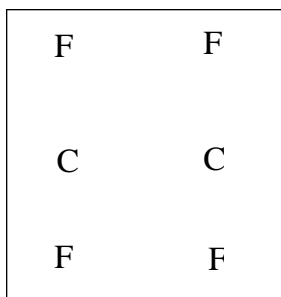

Fill electrons into the framework at the left where there are 4 C-F bonds and a carbon-carbon bond. You decide if the bonds are single, double, triple.

The electron pair geometry around each C atom is _____. The C atom hybridization is _____.

The molecule is *(polar)(nonpolar)* _____.

- (3 points) You have a tank containing all four gases: HF, HCl, CHCl_3 , and CHClF_2 . Place them in order of increasing average velocity at room temperature.

slowest gas

fastest gas

4. (3 points) *Stoichiometry*. The reaction of HF and chloroform proceeds according to the equation



If you mix HF and CHCl_3 in the correct stoichiometric ratio, and the CHCl_3 has a partial pressure of 56 mm Hg (at 25 °C in a flask of given volume), the partial pressure of HF (also at 25 °C in the same flask) must be

- a) 56 mm Hg
 b) 28 mm Hg
 c) 112 mm Hg
 (d) 168 mm Hg
5. (3 points) *Calculating molar mass*. You have a flask containing an unknown chlorofluorocarbon. To determine its molar mass, and therefore identify the compound, you find that 0.103 g has a pressure of 79.3 mm Hg in a 232 mL flask at 21.5 °C. The compound is most likely
- a) CCl_2F_2
 b) CClF_3
 c) CHCl_2F
 d) CHClF_2
6. (3 points) *Bond energies*. Using bond energies (Table 9.9, page 403), calculate the enthalpy change for the synthesis of CHClF_2 .

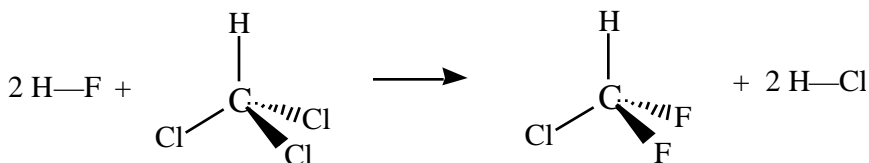

- a) -13 kJ
 b) -26 kJ
 c) -1834 kJ
 d) +26 kJ
 e) +904 kJ
 f) +1808 kJ
 g) None of the above?

KINETICS AND MECHANISMS

1. (4 points) (SQ 15-53) Iodide ion is oxidized in acid solution by hydrogen peroxide.

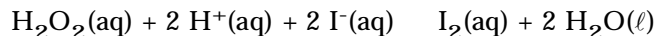

A proposed mechanism is

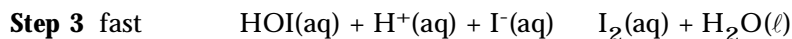
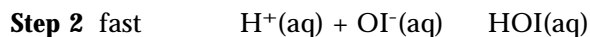
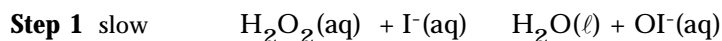

- (a) What is the molecularity of the first step? _____
- (b) Write the rate law for the rate determining step.
- (c) Identify any intermediates in the elementary steps in this reaction. _____
2. (7 points) Radioactive radon-222 (^{222}Rn) from natural sources can seep into the basement of a home. The half-life of ^{222}Rn is 3.8 days.

What is the rate constant for the decay of ^{222}Rn ?

- a) 0.182 day^{-1}
b) 0.263 day^{-1}
c) 3.80 day^{-1}
d) 5.50 day^{-1}

If your basement has 4×10^{13} atoms of ^{222}Rn per liter, and the radon gas is trapped in your basement, how many atoms of ^{222}Rn will remain after 7.6 days? _____ How much will remain after one month (31.0 days)?

- a) 1.2×10^{10} atoms
b) 1.4×10^{11} atoms
c) 1.3×10^{12} atoms
d) 1.0×10^{13} atoms
e) None of the above!

CHEMICAL EQUILIBRIA

1. (10 points) (SQ 16-27) The equilibrium involving CO, Cl₂, and phosgene has been thoroughly studied. (Although quite poisonous, phosgene is a very important industrial intermediate in chemical manufacture.)

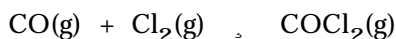

(a) Write the equilibrium constant expression for this reaction.

$$K_c = \text{-----}$$

	[CO]	[Cl ₂]	[COCl ₂]
Initial concentration (M)	0.0102	0.00609	0
Change in concentration (M)			
Equilibrium concentration (M)		0.00301	

(b) A mixture of CO and Cl₂ is placed in a flask. The initial concentrations are given in the table. After equilibrium has been achieved at 600 K, [Cl₂] now has a value of 0.00301 M. **Complete the table above by entering a numerical value in each cell.**

(c) Using the data in your table, calculate the value of K_c.

2. (4 points) An important reaction in the environment and in industry is the *endothermic* decomposition of calcium carbonate.

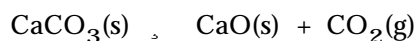

Predict the effect of the following changes on the position of equilibrium; that is, state which way the equilibrium will shift (left, right, or no change) when each of the following changes is made:

a) Adding more CaCO₃ _____

b) Lowering the temperature _____

c) Adding more CO₂ _____

d) Increasing the size of the container for the reaction. _____

ACIDS, BASES, & SOLUBILITY

1. (3 points) Use the acid-base chart to decide on the relative strengths of the following acids:

- (a) acetic acid, $\text{CH}_3\text{CO}_2\text{H}$ (b) HNO_3 (c) ammonium ion (d) H_2S

_____ *weakest*

_____ *strongest*

2. (7 points) *Conjugate acids and bases.*

- a) Consider the reaction of hydrazine with the hydrogen sulfate ion.



On the left side of the equation, the Brønsted acid is _____ and the Brønsted base is _____

- b) Complete and balance the following acid-base reaction:



Does the equilibrium in this reaction lie to the *right* or to the *left*? _____

3. (5 points) Predict the relative pH for each of the following salts. That is, state whether each solution has a pH greater than 7 (>7); less than 7 (<7); or equal to 7 (=7).

(a) Na_2SO_4 _____

(b) LiNO_3 _____

(c) CuCl_2 _____

(d) K_2CO_3 _____

(e) $\text{NaB}(\text{OH})_4$ _____

4. (3 points) Calculate the pH of a 0.10 M solution of ammonium chloride?

(a) 1.80

(b) 2.37

(c) 3.74

(d) 5.12

(e) 11.63

5. (2 points) Acid-Base Reactions

- a) After you mix 5 mL of 0.20 M $\text{CH}_3\text{CO}_2\text{H}$ with 5 mL of 0.20 M KOH , does the resulting solution have a pH = 7, pH < 7, or pH > 7? _____
- b) Does the pH increase, decrease, or stay the same when you add water to a solution of 0.2 M $\text{CH}_3\text{CO}_2\text{H}$ and 0.1 M NaCH_3CO_2 ? _____

6. (3 points) What is the pH of a buffer solution made by adding 24.0 g of NaH_2PO_4 (molar mass = 120 g/mol) and 14.2 g of Na_2HPO_4 (molar mass = 142 g/mol) to 500 mL of water?

- (a) 4.1
- (b) 6.9
- (c) 7.2
- (d) 7.5

7. (2 points) Calcium carbonate, CaCO_3 , is considered very poorly soluble in water. Its solubility can be *estimated* using its K_{sp} value. The calculation assumes that the ions produced, Ca^{2+} and CO_3^{2-} do not react further in solution. What would happen to the solubility of CaCO_3 if some of the carbonate ion reacted with water? Would the solubility increase, decrease, or stay the same? **Explain briefly!**

8. (2 points) Name or give correct formulas for two insoluble salts of the hydroxide ion.

- a) _____
- b) _____

9. (3 points) In each case below, decide if a precipitate will form when mixing the indicated reagents (answer yes or no):

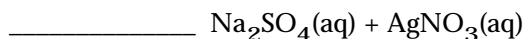
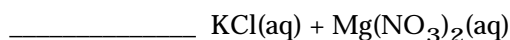
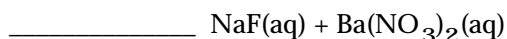

BONUS QUESTION (1 point) What are you going to do this summer? Whatever you do, have a good time!

Name _____

Name _____

Final Exam—Chem 112—Spring 2000—Page 14