

Chapter 9: Theories of Chemical Bonding



Chapter In Context

In the previous chapter we introduced the concept of covalent bonding. In that description, the VSEPR model uses rules for predicting structures that are based on observations of the geometries of many molecules. In this chapter we expand this discussion to understand *why* molecules have these predictable shapes. This deeper understanding involves a model of chemical bonding called valence bond theory and will allow us to predict not only expected structures, but also expected exceptions to the usual rules. In the second major part of this chapter, we examine a second theory of chemical bonding, called molecular orbital theory. Molecular orbital theory can be used to explain structures of molecules but also can explain the energetics of chemical processes, such as what happens when a molecule absorbs a photon of light.

- **In Your World:** Photoreceptor molecules in your eyes allow you to see color. These molecules must absorb light in the visible region of the electromagnetic spectrum and undergo some chemical change when they do. One such molecule, rhodopsin, absorbs light and changes its shape from a *cis* form to a *trans* form. The product of this reaction is shaped such that it initiates an electrochemical signal through neurotransmitters to the brain. The key to rhodopsin being an effective photoreceptor is its ability to return over time to the *cis* form and therefore be able to be used again and again. This ability, we will see in this chapter, arises because the photon of light breaks one of two bonds connecting two carbon atoms in the molecule. The other bond remains intact and keeps the molecule from completely decomposing.

Chapter 9

- 9.1 Introduction to Bonding Theories
- 9.2 Valence Bond Theory
- 9.3 Hybrid Orbitals
- 9.4 Pi Bonding
- 9.5 Conformations and Isomers
- 9.6 Molecular Orbital Theory

Chapter Goals

- Identify major bonding theories.
- Understand basic tenets of valence bond theory.
- Supplement valence bond theory with hybrid orbitals.
- Explain pi bonding in molecules and ions.
- Analyze conformations and isomers.
- Understand basic tenets of molecular orbital theory.

9.1 Introduction to Bonding Theories



OWL Opening Exploration
9.X

As you learned in the previous chapter (Section 8.1), chemical bonds form when two atoms approach each other and the attractive forces are greater than the repulsive forces (Figure 9.1).

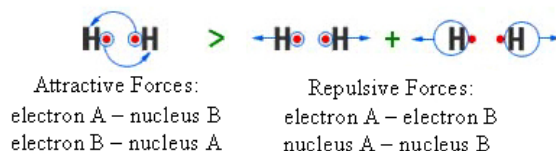

Figure 9.1 Attractive and repulsive forces between 2 atoms

In addition to attractive and repulsive forces and the interatomic distance, chemical bonding is also influenced by the shapes of orbitals in atoms and molecules, the number of valence electrons available in the bonding atoms, and the relative energies of the orbitals involved in bond formation. The two models of chemical bonding that address these factors are **valence bond theory** and **molecular orbital theory**.

Valence bond theory and molecular orbital theory share many assumptions, but also differ in many ways. The two theories are similar in that both assume that

- bonds occur due the sharing of electrons between atoms;
- the attraction of bonding electrons to the nuclei of the bonded atoms leads to lower energy, and therefore the formation of a bond; and
- two types of bonds can form (sigma and pi).

The two theories differ in how they describe the location of the electrons in bonding orbitals, how they explain the energy of electrons, and how they explain the presence of unpaired electrons in molecules.

While molecular orbital theory is the more accurate and more broadly useful of the two theories, valence bond theory is easier to use. For example, valence bond theory predicts shapes of compounds made up of p-block elements. Molecular orbital theory, on the other hand, predicts molecular shapes but only after a more complicated process. Therefore, when discussing the shapes of species made up of p-block elements, chemists invariably use VB theory. When discussing orbital energies, electronic transitions between orbitals, or bonding in, for example, transition metal compounds, chemists use the more complex molecular orbital theory. At times, the two theories are used in concert to describe different aspects of chemical bonding in a single large molecule.

9.2 Valence Bond Theory



OWL Opening Exploration
9.X

The basic tenets of valence bond (VB) theory are

- valence atomic orbitals on adjacent atoms overlap,
- each pair of overlapping valence orbitals is occupied by two valence electrons to form a chemical bond, and
- valence electrons are either involved in bonding between two atoms (shared bonding pairs) or reside on a single atom (nonbonding lone pairs).

Chapter Goals Revisited

- Identify major bonding theories
Compare and contrast valence bond theory and molecular orbital theory.

Chapter Goals Revisited

- Understand basic tenets of valence bond theory.
Explain sigma bonding using valence bond theory.

A covalent bond is the result of the overlap of orbitals on adjacent atoms. The bonding region is the location between the atomic nuclei, where electrons occupy the overlapping orbitals. For example, consider the covalent bond in hydrogen, H_2 (Figure 9.2).

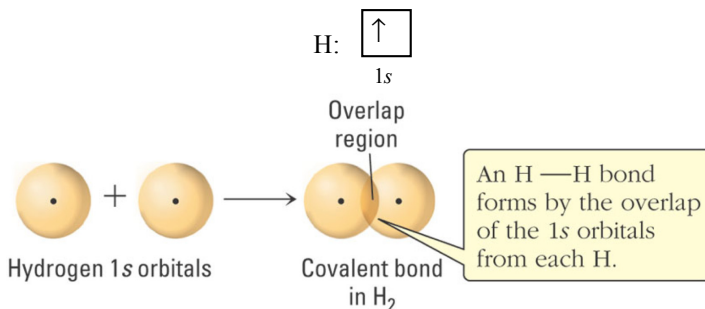

Figure 9.2 The covalent bond in H_2

Each H atom has a single unpaired electron in a 1s orbital ($\text{H}: 1s^1$). The covalent bond in H_2 is the result of the overlap of two 1s atomic orbitals on adjacent H atoms, and each H atom contributes one electron to the covalent bond. The covalent bond forms because of the strong attractive forces between the bonding electrons in the overlapping region and the two H nuclei.

The covalent bond in H_2 is a **sigma (σ) bond** because the bonding region lies along the internuclear axis, the region of space between the nuclei of the bonded atoms. Sigma bonds are not only formed between two s orbitals. Consider the sigma bond in HF (Figure 9.3).

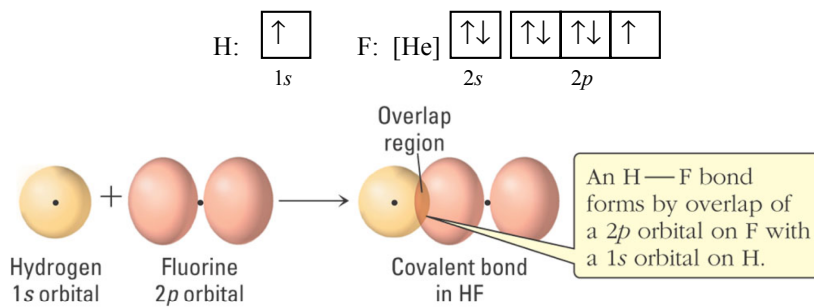

Figure 9.3 The covalent bond in HF

Both hydrogen ($\text{H}: 1s^1$) and fluorine ($\text{F}: [\text{He}]2s^22p^5$) have an unpaired electron in an atomic orbital. The sigma bond that forms between H and F is the result of overlap of a 1s atomic orbital (on H) with a 2p atomic orbital (on F). Each atom contributes one electron to the covalent bond. The H—F bond is a sigma bond because the bonding region lies between the H and F nuclei.

The sigma bond in F_2 is the result of overlap of two 2p atomic orbitals, one from each F atom (Figure 9.4). Each F atom contributes one electron to the covalent bond.

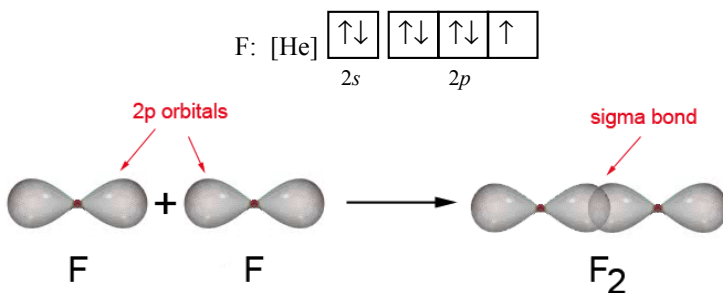

Figure 9.4 The covalent bond in F_2



OWL Concept Exploration
9.3 Sigma Bonding: Tutorial

9.3 Hybrid Orbitals



OWL Opening Exploration
9.X

The atomic orbital overlap model explains covalent bonding in small molecules such as H_2 and HF , but does not work well for larger, more complex molecules. The covalent bonding in methane (CH_4), for example, is not easily explained by the atomic orbital overlap model. While there are four C–H sigma bonds in methane, the electron configuration of carbon shows two unpaired electrons, each in a $2p$ atomic orbital. This suggests that carbon can form no more than two covalent bonds.

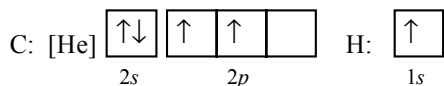

In addition, VSEPR theory predicts that methane has a tetrahedral shape with bond angles of 109.5° , which is not easily explained by the overlap of $2s$ and $2p$ atomic orbitals on carbon with hydrogen $1s$ orbitals. The $2p$ orbitals are arranged at 90° to one another, suggesting that the bond angles in methane should be 90° not 109.5° (Figure 9.5).

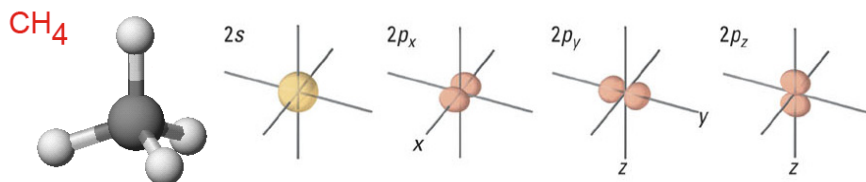

Figure 9.5. CH_4 and the orientation of $2s$ and $2p$ atomic orbitals.

Valence bond theory explains the bonding in molecules such as methane by introducing **hybrid orbitals**, equal-energy orbitals that are the combination of an atom's atomic orbitals. According to valence bond theory, two or more atomic orbitals on a central atom in a molecule “mix” to form an equal number of hybrid orbitals. Each hybrid orbital is a weighted combination of the atomic orbitals that were mixed.

sp^3 Hybrid Orbitals

In methane, one $2s$ and three $2p$ orbitals “mix,” or hybridize, forming four equal-energy hybrid orbitals (Figure 9.6).

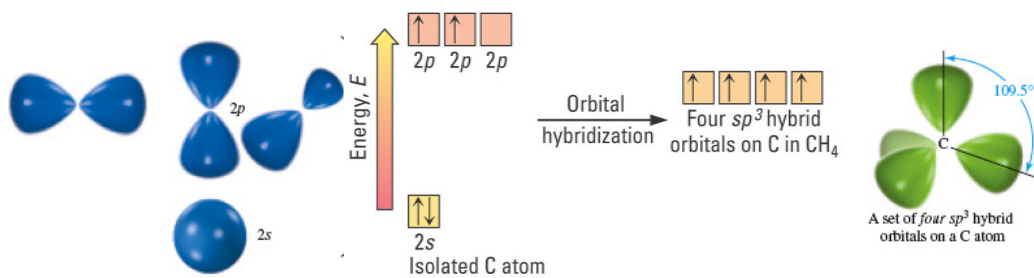

Figure 9.6 Orbital hybridization (sp^3) in CH_4

Chapter Goals Revisited

- Supplement valence bond theory with hybrid orbitals.
Use hybrid orbitals to explain sigma bonding in complex molecules.

Each carbon hybrid orbital is labeled an sp^3 hybrid orbital because it is made up of one part s, one part p_x , one part p_y , and one part p_z atomic orbital. Notice that when four atomic orbitals “mix,” or hybridize, four hybrid orbitals result. The four sp^3 hybrid orbitals arrange so that each points to the corner of a tetrahedron; the angle between any two sp^3 hybrid orbitals is 109.5° .

The C–H sigma bonds in CH_4 result from the overlap of a carbon sp^3 hybrid orbital with a hydrogen 1s atomic orbital. The H 1s orbitals and C sp^3 hybrid orbitals each have one unpaired electron, and four C–H sigma bonds result from hybrid orbital-atomic orbital overlap (Figure 9.7).

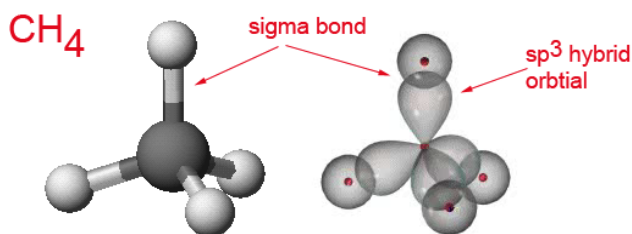

Figure 9.7 Sigma bonding in CH_4

Hybrid orbitals can also be used to explain the bonding on molecules that have lone pairs on the central atom. Consider NH_3 , which has three N–H sigma bonds and a lone pair of electrons on nitrogen (4 structural pairs). The electron pair geometry of ammonia is tetrahedral and the H–N–H bond angle in ammonia is close to 109.5° . Both suggest that the nitrogen atom in ammonia is sp^3 hybridized (Figure 9.8).

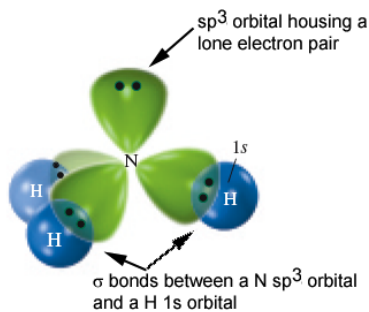
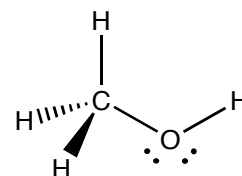

Figure 9.8 Sigma bonding in NH_3

Three of the four sp^3 hybrid orbitals overlap with H 1s atomic orbitals to form sigma bonds. The fourth sp^3 hybrid orbital accommodates the nitrogen lone pair.

Methanol, a molecule with two central atoms, also contains sp^3 hybridized atoms. Both carbon and oxygen have four structural pairs and a tetrahedral electron pair geometry, and both are sp^3 hybridized (Figure 9.9).



Valence Bond Theory and VSEPR Theory Connection

- Four sp^3 hybrid orbitals point at the corners of a tetrahedron.
- Four structural positions are arranged in a tetrahedral electron-pair geometry.

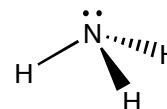

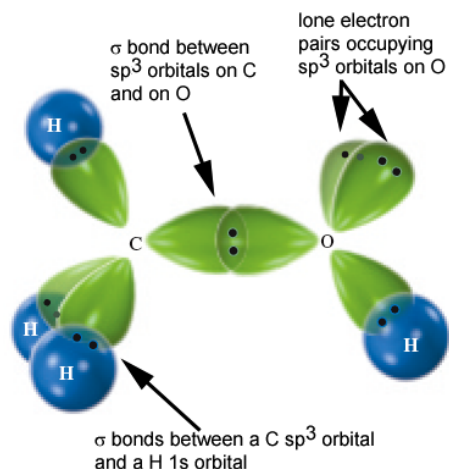
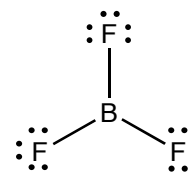
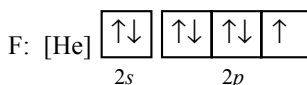
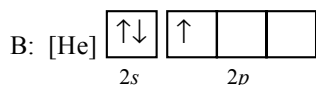

Figure 9.9 Sigma bonding in CH_3OH

Three of the four sp^3 hybrid orbitals on C overlap with H 1s atomic orbitals to form C–H sigma bonds. The C–O sigma bond forms from overlap of a carbon sp^3 hybrid orbital and an oxygen sp^3 hybrid orbital. Two oxygen sp^3 hybrid orbitals accommodate lone pairs, and the fourth oxygen sp^3 hybrid orbital overlaps a H 1s orbital to form the O–H sigma bond. Because both carbon and oxygen are sp^3 hybridized, the bond angles around these atoms are approximately 109° .

sp^2 Hybrid Orbitals

Boron trifluoride, BF_3 , has a trigonal planar geometry with 120° F–B–F bond angles. The electron configuration of boron and the F–B–F bond angles suggest that boron hybridizes when it forms covalent bonds with fluorine



Boron forms three equal-energy hybrid orbitals by combining its three lowest energy valence orbitals, the 2s and two 2p orbitals (Figure 9.10).

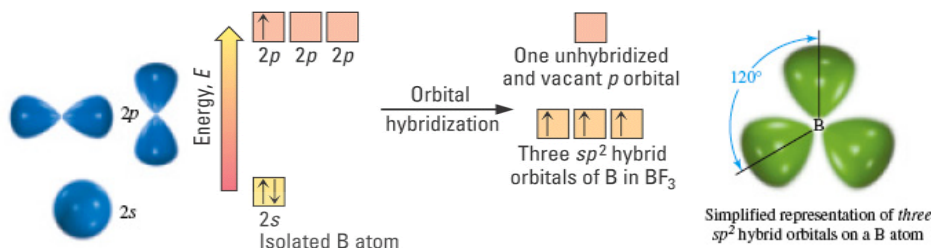

Figure 9.10 Orbital hybridization (sp^2) in BF_3

Each boron hybrid orbital is labeled an sp^2 hybrid orbital because it is made up of one part s and two parts p atomic orbital. One of the boron 2p orbitals does not hybridize; it remains an unhybridized 2p atomic orbital. The three sp^2 hybrid orbitals point at the corners of a triangle; the angle between any two sp^2 hybrid orbitals is 120° .

Each of the three fluorine atoms has a 2p orbital with one unpaired electron and each 2p atomic orbital overlaps a boron sp^2 hybrid orbital, forming three B–F sigma bonds (Figure 9.11).

Valence Bond Theory and VSEPR Theory Connection

- Three sp^2 hybrid orbitals point at the corners of a triangle.
- Three structural positions are arranged in a trigonal planar electron-pair geometry.

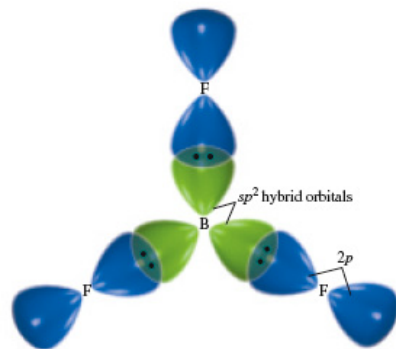
Figure 9.11 Sigma bonding in BF_3

sp Hybrid Orbitals

Beryllium difluoride, BeF_2 , has a linear geometry with an $\text{F}-\text{Be}-\text{F}$ angle of 180° . The electron configuration of beryllium and the $\text{F}-\text{Be}-\text{F}$ angle suggests that beryllium hybridizes when it forms covalent bonds with fluorine.

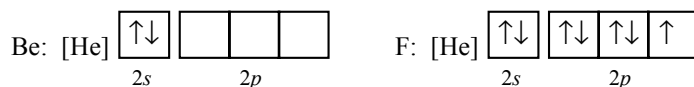
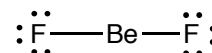

Beryllium forms two equal-energy hybrid orbitals by combining its two lowest energy valence orbitals, the 2s and one 2p orbital (Figure 9.12).

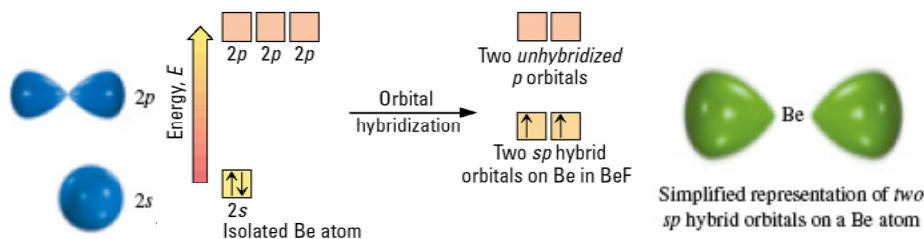
Figure 9.12 Orbital hybridization (sp) in BeF_2

Each beryllium hybrid orbital is labeled an **sp hybrid orbital** because it is made up of one part s and one part p atomic orbital. Two of the beryllium 2p orbitals do not hybridize; they remain unhybridized 2p atomic orbitals. The two sp hybrid orbitals are arranged in a line; the angle between the two sp hybrid orbitals is 180° .

Each of the two fluorine atoms has a 2p orbital with one unpaired electron and each 2p atomic orbital overlaps a beryllium sp hybrid orbital, forming two $\text{Be}-\text{F}$ sigma bonds (Figure 9.13).

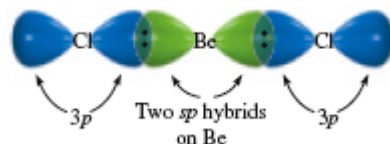
Figure 9.13 Sigma bonding in BeF_2

Valence Bond Theory and VSEPR Theory Connection

- Two sp hybrid orbitals are arranged in a line.
- Two structural positions are arranged in a linear electron-pair geometry.

EXAMPLE PROBLEM: Recognizing Hybridization

Determine the hybridization of all non-hydrogen atoms in the following molecule.

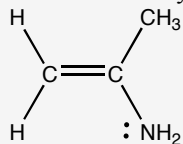
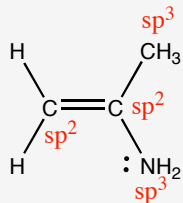
**SOLUTION:**

The two central carbon atoms are sp^2 -hybridized. The carbon on the left has three sigma bonds (two to H atoms and one to the central C atom) and the central carbon has three sigma bonds (one to the left C atom, one to the right C atom, and one to the N atom). Both sp^2 -hybridized carbon atoms have a trigonal planar electron-pair geometry.

The carbon atom on the right is sp^3 -hybridized. This carbon has four sigma bonds (one to the sp^2 -hybridized carbon and three to H atoms) and tetrahedral geometry.

The nitrogen atom is sp^3 -hybridized. It has three sigma bonds (one to the central C atom and two to H atoms) and one lone pair. The nitrogen atom has a tetrahedral electron-pair geometry and a trigonal pyramidal shape.



OWL Example Problems

OWL 9.5 Recognizing Hybridization I: Tutor

OWL 9.6 Recognizing Hybridization II: Tutor

OWL 9.7 Determining Hybrid Orbitals: Tutor

 sp^3d Hybrid Orbitals

As shown in Chapter 8, compounds with a central atom that is an element in the third period or below in the periodic table can have an expanded valence where more than 8 electrons are associated with the central atom. The hybrid orbitals used to form sigma bonds in these compounds include d orbitals. In PF_5 , for example, phosphorus has five structural pairs and therefore forms five hybrid orbitals (Figure 9.14)

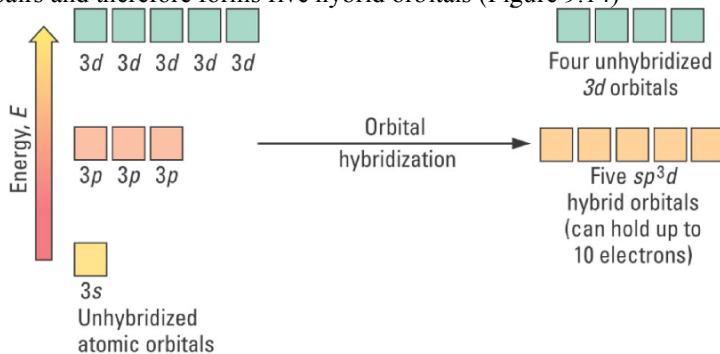
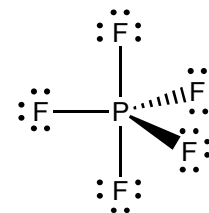

Figure 9.14 Orbital hybridization (sp^3d) in PF_5

Each phosphorus hybrid orbital is labeled an sp^3d hybrid orbital because it is made up of one part s, three parts p, and one part d atomic orbital. The five sp^3d hybrid orbitals point at the corners of a trigonal bipyramid; the angles between any two sp^3d hybrid orbitals are 90° , 120° , or 180° .

Each of the five fluorine atoms has a $2p$ orbital with one unpaired electron and each $2p$ atomic orbital overlaps a phosphorus sp^3d hybrid orbital, forming five P–F sigma bonds (Figure 9.15).

**Valence Bond Theory and VSEPR Theory Connection**

- Five sp^3d hybrid orbitals point at the corners of a trigonal bipyramid.
- Five structural positions are arranged in a trigonal bipyramidal electron-pair geometry.

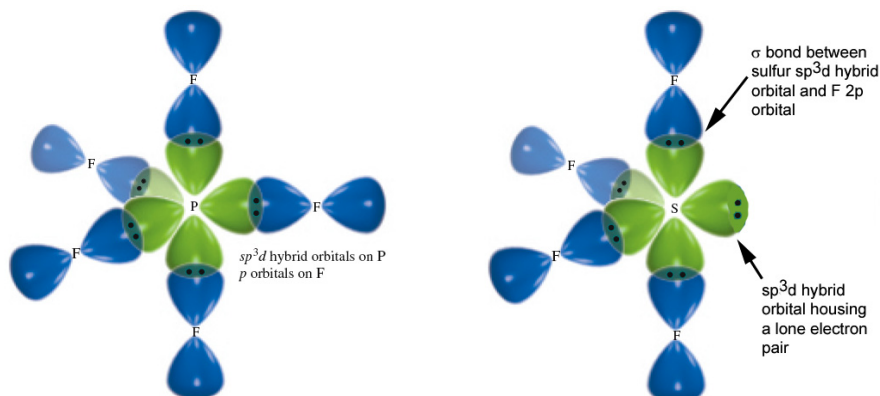
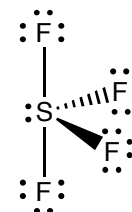

Figure 9.15 Sigma bonding in PF_5 and SF_4

Sulfur tetrafluoride, a molecule with five structural pairs, also has an sp^3d hybridized central atom (Figure 9.x). Four of the five sp^3d hybrid orbitals on S overlap with F 2p atomic orbitals to form four S–F sigma bonds. The fifth sulfur sp^3d hybrid orbital accommodates the lone pair of electrons on sulfur. Recall from VSEPR theory that in a trigonal pyramidal electron-pair geometry, lone pairs occupy equatorial positions.



sp^3d^2 Hybrid Orbitals

Molecules with twelve electrons assigned to the central atom use sp^3d^2 hybrid orbitals to form sigma bonds. In SF_6 , for example, sulfur has six structural pairs and therefore forms six hybrid orbitals (Figure 9.16)

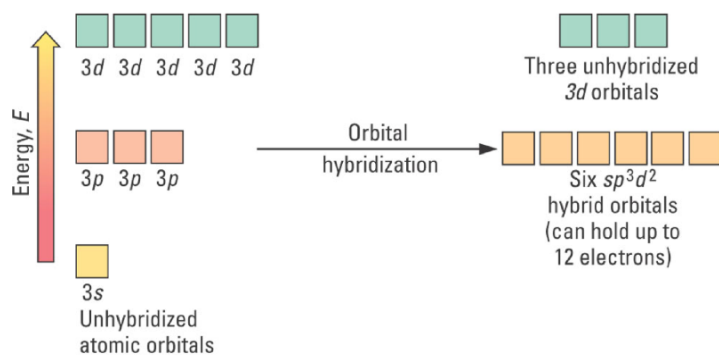
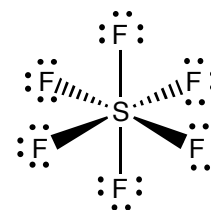

Figure 9.16 Orbital hybridization (sp^3d^2) in SF_6

Each sulfur hybrid orbital is labeled an sp^3d^2 hybrid orbital because it is made up of one part s, three parts p, and two parts d atomic orbital. The six sp^3d^2 hybrid orbitals point at the corners of an octahedron; the angles between any two sp^3d^2 hybrid orbitals are 90° or 180° .

Each of the six fluorine atoms has a 2p orbital with one unpaired electron and each 2p atomic orbital overlaps a sulfur sp^3d^2 hybrid orbital, forming six S–F sigma bonds (Figure 9.17).



Valence Bond Theory and VSEPR Theory Connection

- Six sp^3d^2 hybrid orbitals point at the corners of an octahedron.
- Six structural positions are arranged in an octahedral electron-pair geometry.

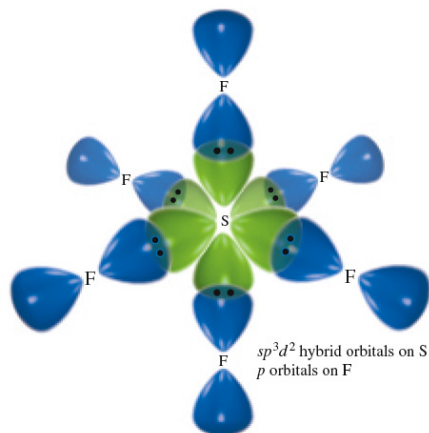

Figure 9.17 Sigma bonding in SF₆

Table 9.1 summarizes the relationship between the hybridization of a central atom and the number of structural pairs on the hybridized atom.

Table 9.1 Relation Between Structural Pairs and Hybridization

Number of Structural Pairs on Central Atom	Electron Pair Geometry	Atomic Orbitals Mixed to Form Hybrid Orbitals	Hybridization
2	linear	one s, one p	sp
3	trigonal planar	one s, two p	sp ²
4	tetrahedral	one s, three p	sp ³
5	trigonal bipyramidal	one s, three p, one d	sp ³ d
6	octahedral	one s, three p, two d	sp ³ d ²

To chemists, hybridization and electron-pair geometry terms are synonymous. For example, the terms “sp²” and “trigonal planar geometry” provide the same information about the geometry and sigma bonding of an atom in a molecule or ion.

EXAMPLE PROBLEM: Identify Sigma Bonding

Answer the following questions about SO₃.

- What is the hybridization of the sulfur atom in SO₃?
- What orbitals make up the sigma bond between S and O in SO₃?
- What are the approximate bond angles in SO₃?

SOLUTION:

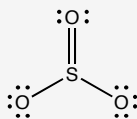

The Lewis structure of SO₃ is

- The sulfur atom in SO₃ has three sigma bonds and no lone pairs. It is sp² hybridized.
- Oxygen atoms have an unpaired electron in a 2p orbital. The S-O sigma bonds result from overlap of a 2p orbital on oxygen with one of the sp² hybrid orbitals on sulfur.
- Sulfur is sp² hybridized and therefore has a trigonal planar electron pair geometry. The O–S–O bond angles are 120°.



OWL Example Problems

OWL 9.8 Hybrid Orbitals

OWL 9.9 Identify Sigma Bonding

OWL 9.10 Molecules and Hybridization

9.4 Pi Bonding



OWL Opening Exploration
9.X

Earlier, we defined a sigma bond as a covalent bond where the bonding region lies along the internuclear axis, between the nuclei of the bonded atoms. A **pi (π) bond** occurs when the two orbitals overlap to form a bond where the bonding region is above and below the internuclear axis. Pi bonds can form when two unhybridized p orbitals on adjacent atoms overlap (Figure 9.18).

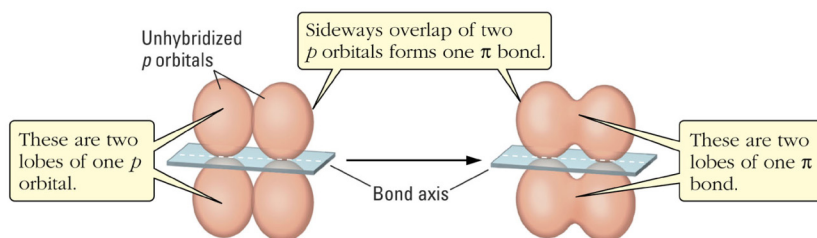

Figure 9.18 Pi bond formation from two p orbitals

The sideways overlap of two p orbitals to form a pi bond is less effective and results in a weaker bond than the sigma bond formed by direct, head-on overlap of atomic or hybrid orbitals. As a result, a single, two-electron bond between two atoms is always a sigma-type bond. When two or more covalent bonds form between two atoms, one is always a sigma bond and the additional bonds are pi bonds.

Ethene, C_2H_4

Each C atom in ethene is sp^2 hybridized, and each sp^2 hybrid orbital is used to form a sigma bond to another atom (Figure 9.19).

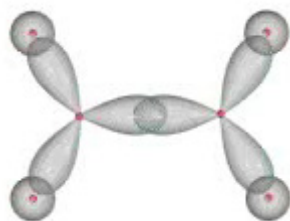

Figure 9.19 Sigma bonding in C_2H_4

The sp^2 -hybridized carbon atoms in ethene each have an unhybridized p orbital that is not involved in sigma bonding and that contains a single electron (Figure 9.20).

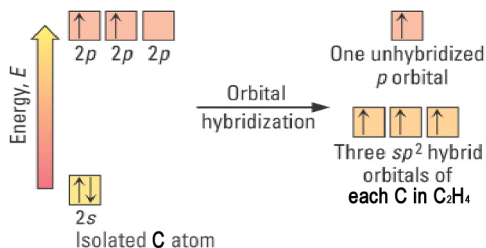
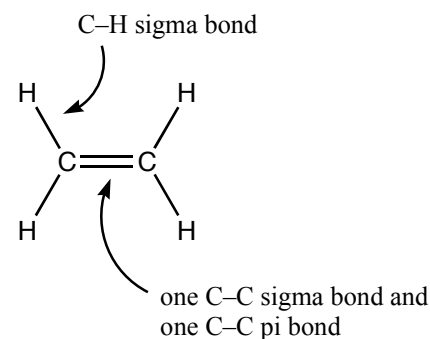

Figure 9.20 Hybrid orbitals for each carbon atom in C_2H_4

The unhybridized 2p orbitals are used to form a pi bond between the two carbon atoms (Figure 9.21). The pi bond is a 2-electron bond, like a sigma bond, and it lies above and below the plane containing the sigma bonds in ethene.

Chapter Goals Revisited

- Explain pi bonding in molecules and ions.
- Use valence bond theory to explain pi overlap between p orbitals.**



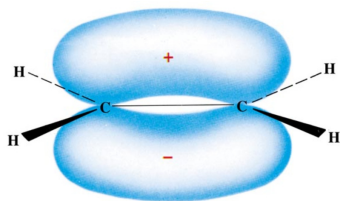

Figure 9.21 Pi bonding in C_2H_4

Notice that the sideways alignment of the p orbitals that overlap to form the pi bond result in a flat (planar) molecular shape for ethene. A complete picture of the sigma and pi bonding in ethene is shown in Figure 9.22.

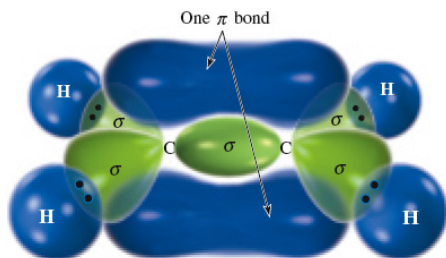

Figure 9.22. Sigma and pi bonding in C_2H_4

Acetylene, C_2H_2

Each C atom in acetylene is sp hybridized, and each sp hybrid orbital is used to form a sigma bond to another atom (Figure 9.23)



Figure 9.23 Sigma bonding in C_2H_2

The sp -hybridized carbon atoms in acetylene each have two unhybridized p orbitals that are not involved in sigma bonding, and each contains a single electron (Figure 9.24).

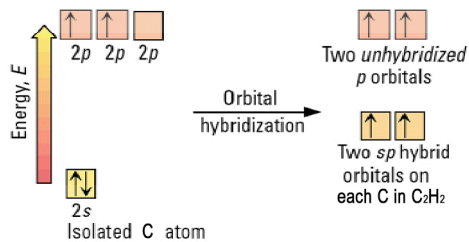
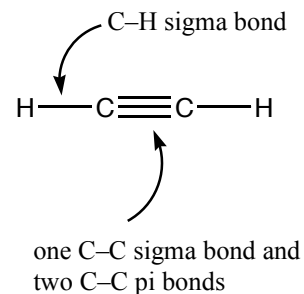

Figure 9.24 Hybrid orbitals for each carbon atom in C_2H_2

Each pair of unhybridized 2p orbitals (one 2p orbital from each carbon atom) forms a pi bond between the carbon atoms. There are two pairs of unhybridized 2p orbitals, so two pi bonds are formed. The two pi bonds are oriented 90° from each other because the unhybridized 2p orbitals on each carbon are at 90° from each other. A complete picture of the sigma and pi bonding in acetylene is shown in Figure 9.25.



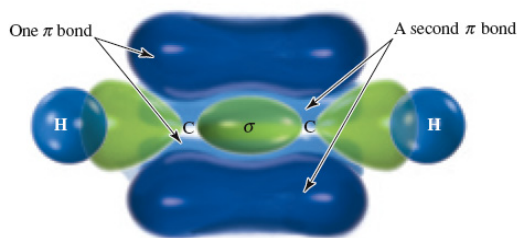
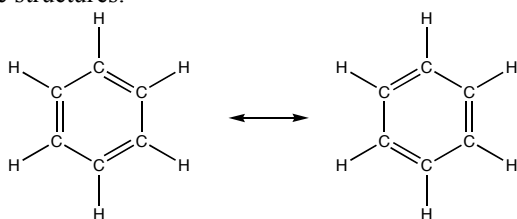

Figure 9.25. Sigma and pi bonding in C_2H_2

Benzene, C_6H_6

The cyclic compound benzene is one of the most important organic molecules. The molecule is composed of six carbon atoms in a ring with alternating single and double bonds, and each carbon also bonds to a single hydrogen atom. Benzene has two equivalent resonance structures.



Each C atom in benzene is sp^2 hybridized and the sp^2 hybrid orbitals are used to form sigma bonds to two carbon atoms and one hydrogen atom. The trigonal planar electron pair geometry around each carbon atom results in a planar ring structure (Figure 9.26).

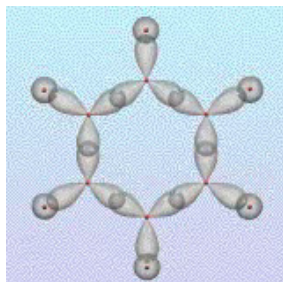

Figure 9.26 Sigma bonding in benzene (dots represent nuclei).

Like ethene, each sp^2 -hybridized carbon atom in benzene has an unhybridized p orbital that is used to form pi bonds, and the pi bonds lie above and below the plane containing the carbon-carbon and carbon-hydrogen sigma bonds. The pi bonding in benzene is more complex than ethene, however, due to the benzene resonance structures. The two equivalent resonance structures for benzene indicate that the molecule does not have three pi bonds that are each localized between two carbon atoms. Instead, the six unhybridized p orbitals on carbon form one delocalized pi bonding system that lies above and below the plane of the molecule (Figure 9.27).

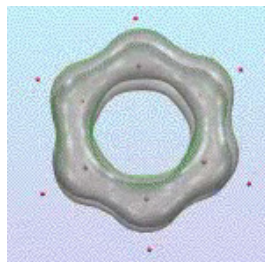

Figure 9.27 Pi bonding system in benzene (dots represent nuclei).

While it is often difficult to represent the resonance hybrid for a molecule, chemists often use a ring when drawing the structure of benzene to represent the delocalized pi bonding system (Figure 9.28).

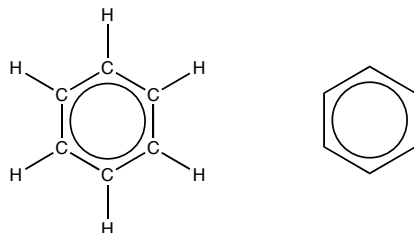

Figure 9.28 Representations of benzene resonance hybrid

Viewing the sigma and pi system in benzene together shows the planar shape of the molecule and the delocalized pi electron density that lies above and below the plane of the molecule (Figure 9.29).

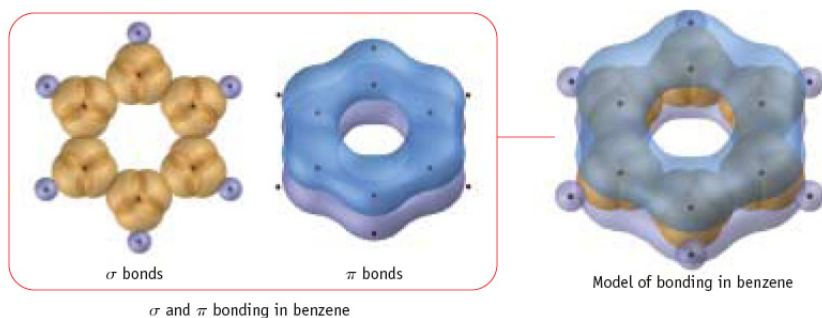

Figure 9.29 Sigma and pi bonding in benzene



OWL Concept Exploration
OWL 9.12: Exercise: Bonding in Benzene

As shown in the previous examples, the number of pi bonds that an atom forms is related to the number of unhybridized p orbitals available. The relationship between atom hybridization and the number of possible pi bonds is shown in Table 9.2.

Table 9.2 Relationship Between Hybridization and Number of Possible Pi Bonds

Number of Structural Pairs on Central Atom	Hybridization	Unhybridized p Orbitals	Number of Possible Pi Bonds
2	sp	two p	2
3	sp^2	one p	1
4	sp^3	none	0
5	sp^3d	none	0
6	sp^3d^2	none	0

EXAMPLE PROBLEM: Determining Hybrid Orbitals and Pi Bonding

How many sigma and pi bonds are in the following molecule?

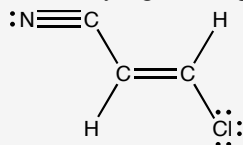
**SOLUTION:**

Each line represents a 2-electron bond. A single bond (one line) represents a sigma bond; a double bond (two lines) represents one sigma bond and one pi bond; a triple bond (three lines) represents one sigma bond and two pi bonds.

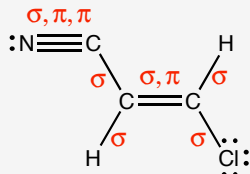

There are six sigma bonds and three pi bonds in the molecule.



OWL Example Problems
 OWL 9.14 Pi Bonding: Tutor
 OWL 9.15 Pi Bonding

9.5 Conformations and Isomers

The presence or absence of pi bonds in a molecule affects its physical properties. For example, acetylene, C_2H_2 , has two pi bonds and reacts with H_2 , while ethane, C_2H_6 , has no pi bonds and does not react with H_2 . In addition, pi bonds affect the physical shape of a molecule, which relates to the number of possible conformations and isomers a molecule can adopt.

Conformations are the different three-dimensional arrangements of atoms in a molecule that can be interconverted by rotation around single bonds. Consider the butane conformations shown in Figure 9.30. Each differs only in the orientation of the right side of the molecule. The structures were generated by rotating one half of the molecule with respect to the other half, around the carbon-carbon sigma bond.

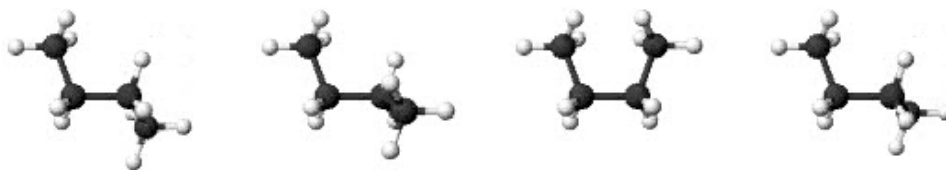

Figure 9.30 Butane conformations

Carbon-carbon sigma bond rotation in butane occurs easily because a sigma bond has bonding electron density directly between two bonded atoms. Rotation around a sigma bond does not affect the bonding electrons that lie between the bonded nuclei. There is no limit to the number of possible conformations of a butane molecule, and the ends of the molecule rotate freely at room temperature [Figure 9.31(a)].

Isomers are two or more substances that have the same chemical formula but have different properties because of the different arrangement of atoms. Molecules with pi bonds are one example of compounds that can exist as more than one isomer. Consider the bond rotation in a molecule containing a pi bond. Because a pi bond has electron density both above and below the internuclear axis, a pi bond cannot rotate freely. Rotation around a double bond (a sigma bond and a pi bond) results in breaking the pi

Chapter Goals Revisited

- Analyze conformations and isomers.
- Understand effect of sigma and pi bonds on conformations and isomers.**

bond, a process that requires a significant amount of energy. Such free rotation therefore does not happen at room temperature [Figure 9.31(b)].

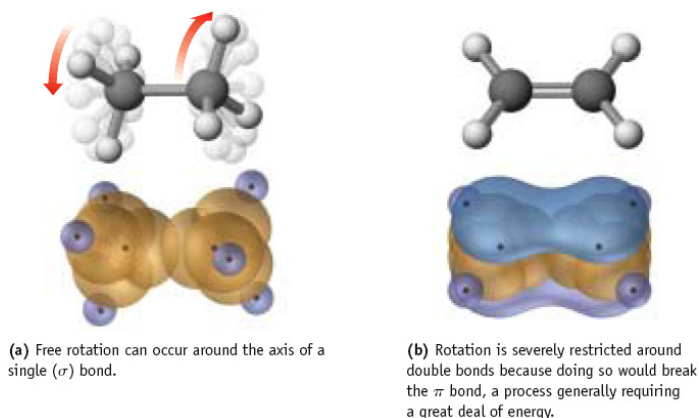
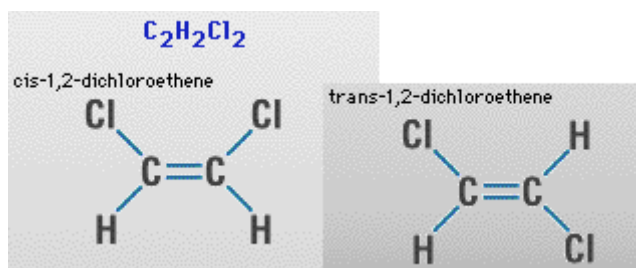

Figure 9.31 Rotation around a single bond and a double bond

The energy barrier that prevents rotation of pi bonds means that two isomers that differ by rotation about the pi bond will not easily interconvert at room temperature. Consider the two possible isomers of 1,2-dichloroethane.



These two structures differ only in the placement of the Cl and H atoms about the C=C double bond. In the structure labeled *cis*, both Cl atoms are on the same side of the double bond, while in the structure labeled *trans*, the Cl atoms are on opposite sides of the double bond. These two structures cannot interconvert easily because doing so would require breaking the C-C pi bond, and therefore the two structures represent two unique isomers.

EXAMPLE PROBLEM: Identifying Isomers and Conformations

Consider the follow set of molecules. Gray spheres represent carbon, white spheres represent hydrogen, and green spheres represent chlorine atoms. Which pairs represent conformations of the same molecule and which pairs represent isomers?

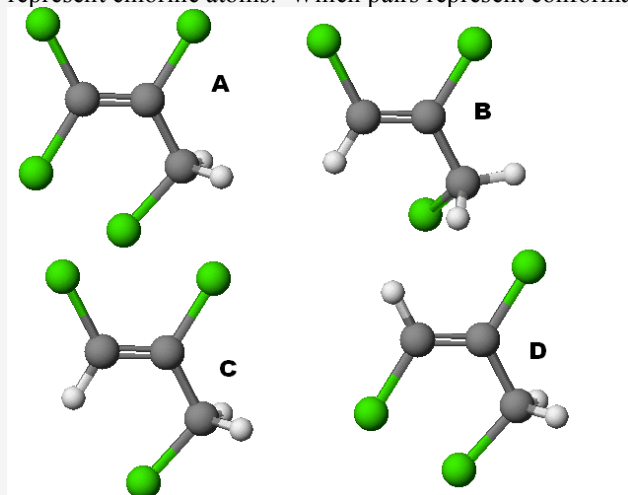
**SOLUTION:**

B and C are conformations of the same compound. They have the same chemical formula ($C_3H_3Cl_3$) and are related by rotation around a carbon-carbon single bond.

C and D are isomers. They have the same chemical formula ($C_3H_3Cl_3$) and are related by rotation around a carbon-carbon double bond. C is the *cis* isomer and D is the *trans* isomer.

B and D are also isomers. B is the *cis* isomer and D is the *trans* isomer. They are related by rotation around a carbon-carbon double bond and rotation around a carbon-carbon single bond.

A is a unique compound ($C_3H_2Cl_4$).



OWL Example Problems

OWL 9.16 Identifying Isomers and Conformations: Exercise

Chapter Goals Revisited

- Understand basic tenets of molecular orbital theory.

Explain sigma bonding and antibonding molecular orbitals.

9.6 Molecular Orbital Theory

Molecular orbital (MO) theory is similar in many ways to valence bond theory. Bond formation is viewed in a similar manner, where overlapping orbitals on different atoms increase attractive forces between electrons and nuclei. The two theories differ, however, in how the resulting orbital combinations are viewed. In valence bond theory, orbitals in a molecule are thought to be localized on atoms, with some overlap of the orbitals between bonded nuclei. In the molecular orbital view, orbitals in a molecule are thought to be spread out (delocalized) over many atoms. Valence bond theory is often referred to as a localized bonding theory while molecular orbital theory is referred to as a delocalized bonding theory. One of the most important and unique aspects of molecular orbital theory is its ability to predict the shapes and energies of orbitals that contain no electrons. That is, molecular orbital theory not only explains how electrons are arranged in the ground state, but also how they might be arranged in an excited electronic state.

Sigma Bonding and Antibonding Molecular Orbitals

According to MO theory, when any number of atomic orbitals overlap to form molecular orbitals, an equal number of molecular orbitals are formed. When two s orbitals overlap, for example, they form two new orbitals: one at lower energy than the original s orbitals and one at higher energy than the original s orbitals.

Consider the formation of H_2 . Each H atom has a single electron in a 1s orbital. Adding the two 1s orbitals together results in the formation of a **bonding molecular orbital** (Figure 9.32) that increases the electron density between the bonded nuclei. This

bonding MO is a sigma (σ) molecular orbital because electron density lies along the internuclear axis. It is labeled σ_{1s} to indicate the atomic orbitals that contributed to form the molecular orbital. This molecular orbital is lower in energy than the separated hydrogen 1s orbitals because electrons occupying this orbital experience increased attractive forces to the hydrogen nuclei.

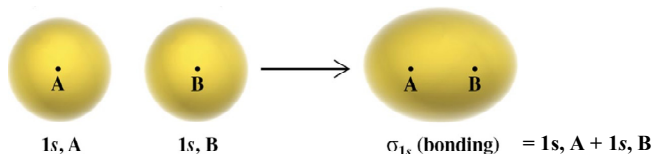

Figure 9.32 Bonding (σ_{1s}) molecular orbital

Subtracting the two 1s orbitals results in the formation of an **antibonding molecular orbital** (Figure 9.33) that decreases the electron density between the bonded nuclei. This bonding MO is a sigma (σ) molecular orbital because electron density lies along the internuclear axis. It is labeled σ^*_{1s} to indicate its antibonding nature and to identify the atomic orbitals that contributed to form the molecular orbital. This molecular orbital is higher in energy than the separated hydrogen 1s orbitals because electrons occupying this orbital experience decreased attractive forces to the hydrogen nuclei. In addition, the antibonding molecular orbital has a node, a plane on which there is zero probability for finding an electron.

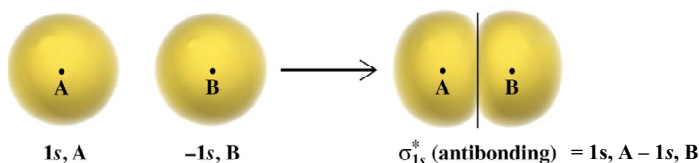

Figure 9.33 Antibonding (σ^*_{1s}) molecular orbital

Sigma bonding and antibonding MOs can also form from the interactions of p orbitals. When two 2p orbitals are added and subtracted in a head-on alignment, along the internuclear axis, one sigma bonding (σ_{2p}) molecular orbital and one sigma antibonding (σ^*_{2p}) molecular orbital results (Figure 9.34).

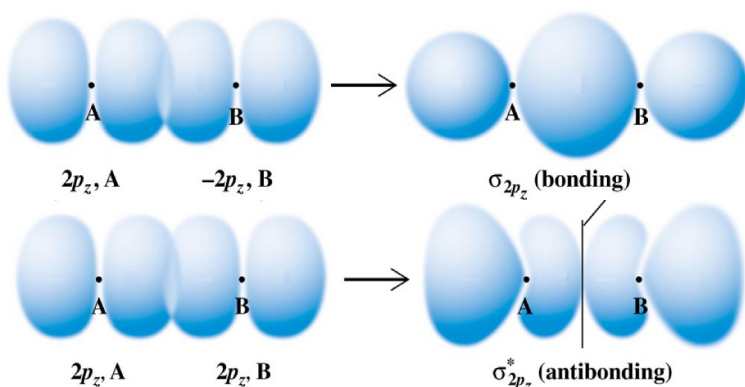

Figure 9.34 Bonding (σ_{sp}) and antibonding (σ^*_{2p}) molecular orbitals

Notice the formation of a new planar node in the antibonding (σ^*_{2p}) molecular orbital

Pi Bonding and Antibonding Molecular Orbitals

Just as in VB theory, pi (π) molecular orbitals result from the sideways overlap of p orbitals. When two 2p orbitals are added and subtracted, a pi bonding orbital and a pi antibonding orbital form (Figure 9.35). The π_{2p} molecular orbital is lower in energy than

the original 2p orbitals; the π^*_{2p} molecular orbital is higher in energy (less stable) than the original 2p orbitals.

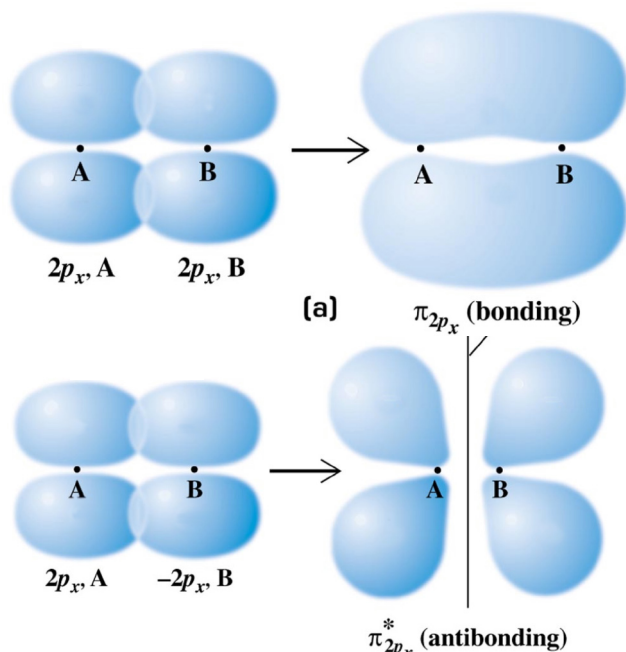

Figure 9.35 Bonding (π_{2p}) and antibonding (π^*_{2p}) molecular orbitals

Because there are two 2p orbitals on each atom that can overlap to form pi bonds, a total of four pi molecular orbitals are possible, two pi bonding molecular orbitals (π_{2p}) and two pi antibonding molecular orbitals (π^*_{2p}).



OWL Concept Exploration
OWL 9.19: Bonding and Antibonding Orbitals: Exercise

Molecular Orbital Diagrams (H_2 and He_2)

One of the strengths of molecular orbital theory is its ability to describe the energy of both occupied and unoccupied molecular orbitals for a molecule. A **molecular orbital diagram** shows both the energy of the atomic orbitals (from the atoms that are combining) and the energy of the molecular orbitals.

Consider the molecular orbital diagram for H_2 (Figure 9.36).

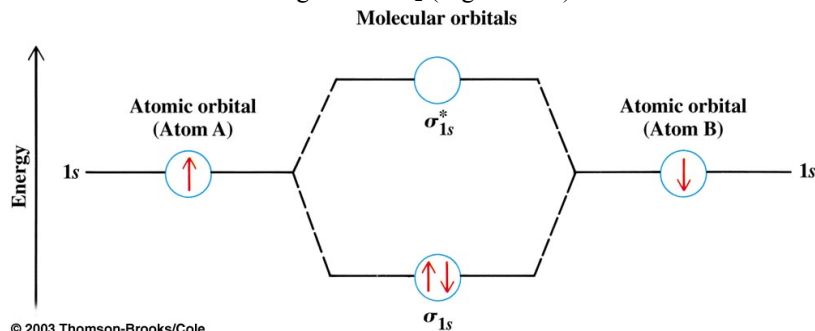

Figure 9.36 Molecular orbital diagram for H_2

Notice the following features of the H_2 molecular orbital diagram.

Chapter Goals Revisited

- Understand basic tenets of molecular orbital theory.
Explain pi bonding and antibonding molecular orbitals.

Chapter Goals Revisited

- Understand basic tenets of molecular orbital theory.
Draw molecular orbital diagrams for diatomic species.

- The atomic orbitals are placed on the outside of the diagram and the molecular orbitals are placed between the atomic orbitals, in the center of the diagram.
- Valence electrons are shown in atomic orbitals and electrons are assigned to molecular orbitals according to the Pauli exclusion principle and Hund's rule.
- Dashed lines are used to connect molecular orbitals to the atomic orbitals that contribute to their formation.
- Bonding molecular orbitals are lower in energy than the atomic orbitals that contribute to their formation.
- Antibonding molecular orbitals are higher in energy than the atomic orbitals that contribute to their formation.

The electron configuration for H_2 is written $(\sigma_{1s})^2$, showing the presence of two electrons in the σ_{1s} molecular orbital. The molecular orbital diagram for dihelium (He_2) is the same as that of hydrogen, with the addition of two more electrons (Figure 9.37).

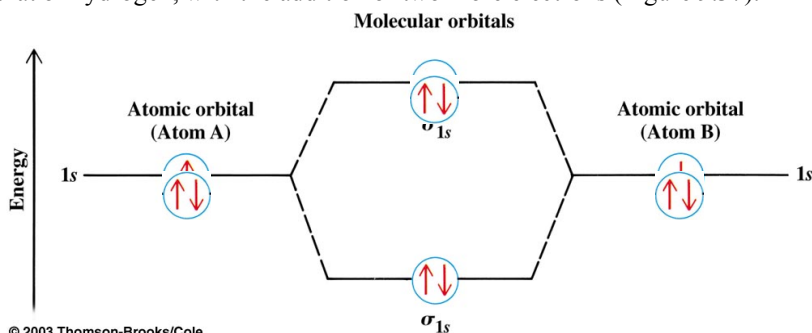

Figure 9.37 Molecular orbital diagram for He_2

The electron configuration for dihelium is $(\sigma_{1s})^2(\sigma^*_{1s})^2$.

Molecular orbital diagrams provide a method for determining the **bond order** between two atoms in a molecule.

$$\text{Bond order} = \frac{1}{2} [\text{number of electrons in bonding orbitals} - \text{number of electrons in antibonding orbitals}] \quad (9.1)$$

$$\text{H-H bond order in } H_2 = \frac{1}{2} [2 - 0] = 1$$

$$\text{He-He bond order in } He_2 = \frac{1}{2} [2 - 2] = 0$$

The bond order in H_2 is the same as that predicted from its Lewis dot structure. The bond order in He_2 is zero, suggesting that this molecule probably does not exist.

Calculated bond orders for other hydrogen and helium species (Figure 9.38) suggest that H_2^+ , H_2^- , and He_2^+ have weak bonds (bond order = 0.5) and are predicted to exist.

Species	H_2^+	H_2	H_2^-	He_2^+	He_2
σ^*	\square	\square	\uparrow	\uparrow	$\uparrow\downarrow$
σ	\uparrow	$\uparrow\downarrow$	$\uparrow\downarrow$	$\uparrow\downarrow$	$\uparrow\downarrow$
# bonding electrons	1	2	2	2	2
# antibonding electrons	0	0	1	1	2
bond order	0.5	1.0	0.5	0.5	0

Figure 9.38 Molecular orbital diagram for species containing H and He

Molecular Orbital Diagrams ($Li_2 - F_2$)

The homonuclear diatomic molecules of the second period, $Li_2 - F_2$, have both 2s and 2p valence atomic orbitals. The molecular orbital diagram for the second row homonuclear

Flashback

8.4 Bond Properties

Chapter Goals Revisited

- Understand basic tenets of molecular orbital theory.

Predict electron configuration and bond properties for diatomic species.

diatomics (Figure 9.39), therefore shows the formation of molecular orbitals formed from overlap of these atomic orbitals.

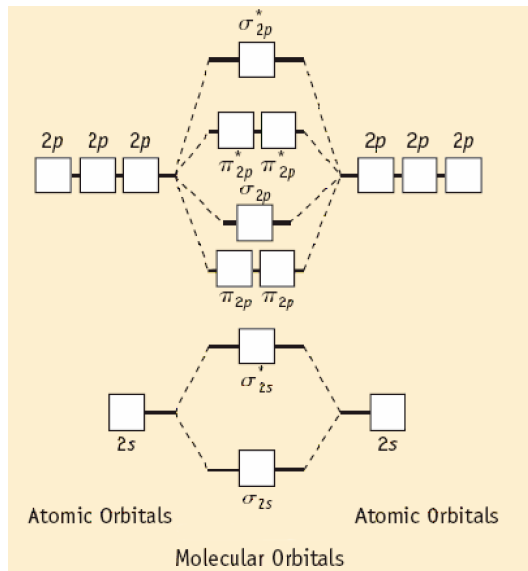

Figure 9.39 Molecular orbital diagram for homonuclear diatomics

Notice the following features of the molecular orbital diagram for the 2nd row homonuclear diatomics.

- Only the valence atomic orbitals and resulting valence molecular orbitals are shown in the molecular orbital diagram.
- Each atom contributes 4 atomic orbitals (2s and three 2p orbitals), resulting in the formation of 8 molecular orbitals.
- There are two π_{2p} molecular orbitals (of equal energy) and two π^*_{2p} molecular orbitals (of equal energy).

The homonuclear molecular orbital diagram for oxygen, O₂, is shown in Figure 9.40.

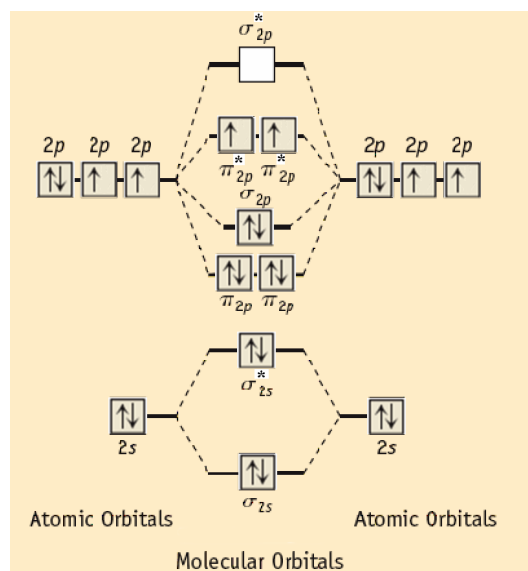
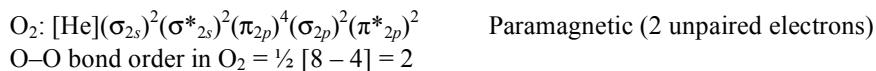

Figure 9.40 Molecular orbital diagram for O₂

The molecular orbital diagram shows that the O–O bond order is 2 and that oxygen is paramagnetic with two unpaired electrons.

Flashback
7.1 Electron Spin and Magnetism



As shown in Figure 9.41, in its liquid state O_2 is attracted to a strong magnet. Notice that valence bond theory and Lewis dot structures do not explain why liquid oxygen is attracted to a magnetic field. This is one example of the more accurate nature of molecular orbital theory.



Figure 9.41 Liquid oxygen adheres to the poles of a strong magnet.

Abbreviated molecular diagrams for some of the second row homonuclear diatomics are shown in Figure 9.42.

σ_{2p}^*					
π_{2p}^*					
σ_{2p}					
π_{2p}					
σ_{2s}^*					
σ_{2s}					
species	B_2	C_2	N_2	O_2	F_2
# bonding electrons	4	6	8	8	8
# antibonding electrons	2	2	2	4	6
bond order	1	2	3	2	1

Figure 9.42 Molecular orbital diagrams for $\text{Li}_2 - \text{F}_2$

EXAMPLE PROBLEM: Homonuclear Diatomic Molecules

What is the Ne–Ne bond order in Ne_2 and Ne_2^+ ?

SOLUTION:

To answer this question, the homonuclear diatomic MO diagram must be filled in with the appropriate number of electrons. The diagram below on the left is filled in for Ne_2 , which has a total of 8 bonding electrons and 8 antibonding electrons. The bond order is therefore 0. In Ne_2^+ , however, there are only 7 antibonding electrons, and the bond order is 0.5.

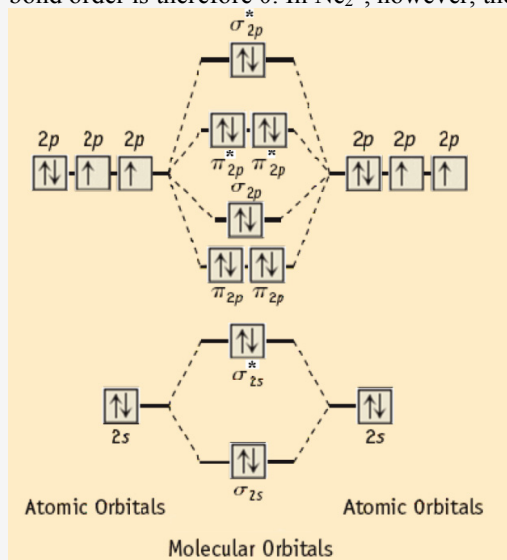

$$\text{Ne}_2: \text{Bond order} = \frac{1}{2} [8 - 8] = 0$$

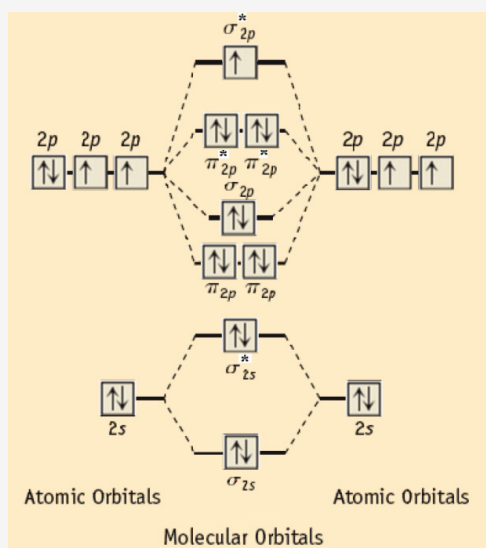

$$\text{Ne}_2^+: \text{Bond order} = \frac{1}{2} [8 - 7] = 0.5$$



OWL Example Problems

OWL 9.20: Homonuclear Diatomic Molecules: Tutor

OWL 9.21: Paramagnetism: Tutor

OWL 9.22: Homonuclear Diatomic Molecules

Molecular Orbital Diagrams (Heteronuclear Diatomics)

The molecular orbital diagram for the heteronuclear diatomic compound nitrogen monoxide, NO, is shown in Figure 9.43.

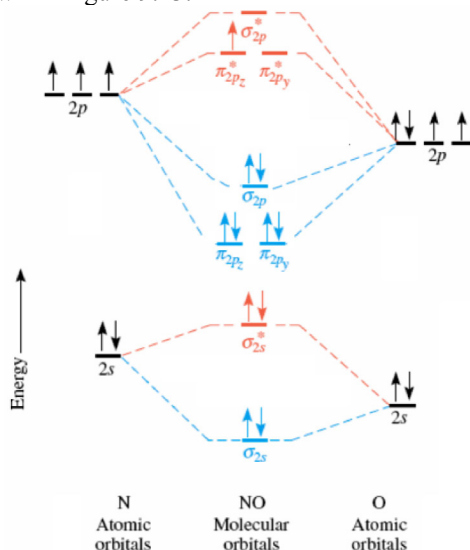
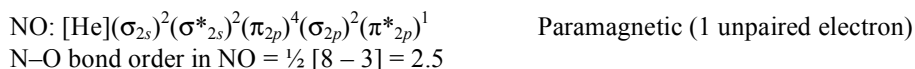

Figure 9.43 Molecular orbital diagram for nitrogen monoxide



Notice that the heteronuclear diatomic diagram is very similar to the homonuclear diagram. For example, the diagrams have the same types of molecular orbitals (sigma and pi, bonding and antibonding). However, the energy of the valence atomic orbitals is not the same. Oxygen is more electronegative than nitrogen and its atomic orbitals are lower in energy.

Molecular Orbital Diagrams (More Complex Molecules)

Most molecules are much more complex than those we have examined here. Molecular orbital theory has proved to be very powerful in interpreting and predicting the bonding in virtually all molecules. The molecular orbital diagram for a slightly more complex compound, methane (CH_4) is shown in Figure 9.44.

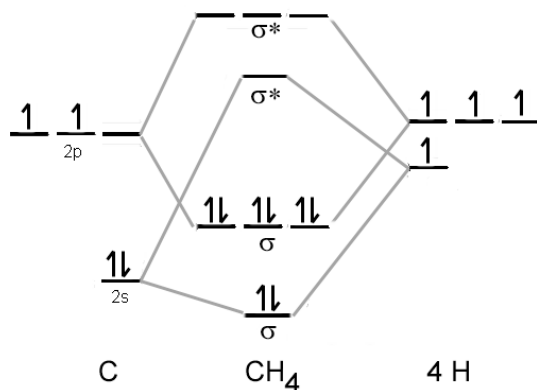

Figure 9.44 Molecular orbital diagram for methane

Flashback
7.2 Orbital Energy

While the diagram does not greatly resemble that of the diatomics, it is possible to recognize that the diagram shows four sigma bonding molecular orbitals, each with two electrons. This diagram therefore reinforces the valence bond theory model of methane, with four C–H sigma bonds (Figure 9.45).

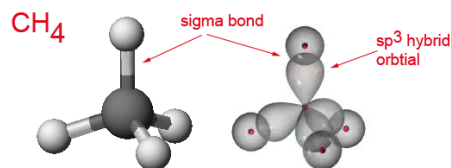

Figure 9.45 Valence bond theory model of methane

Today, although molecular orbital diagrams for complex molecules can be developed on paper, usually computer-driven “molecular modeling” programs are used to calculate molecular orbital shapes and energies. These programs do not always work flawlessly, however, and their results must be compared to experimental information.

Chapter Review



OWL Summary Assignments

9.23 Chapter Review

9.24 Challenge Problems

Key Equations

$$\text{Bond order} = \frac{1}{2} [\text{number of electrons in bonding orbitals} - \text{number of electrons in antibonding orbitals}] \quad (9.1)$$

Key Terms

9.1 Introduction to Bonding Theories

valence bond theory
molecular orbital theory

9.2 Valence Bond Theory

sigma (σ) bond

9.3 Hybrid Orbitals

hybrid orbitals
 sp^3 hybrid orbital
 sp^2 hybrid orbital
 sp hybrid orbital
 sp^3d hybrid orbital
 sp^3d^2 hybrid orbital

9.4 Pi Bonding

pi (π) bond

9.5 Conformations and Isomers

Conformations
Isomers

9.6 Molecular Orbital Theory

bonding molecular orbital
antibonding molecular orbital
molecular orbital diagram
bond order

Chapter 10: Gases



Chapter 10

- 10.1 Properties of Gases
- 10.2 Historical Gas Laws
- 10.3 The Ideal and Combined Gas Laws
- 10.4 Dalton's Law of Partial Pressures
- 10.5 Gas Laws and Stoichiometry
- 10.6 Kinetic Molecular Theory
- 10.7 Non-Ideal Gases

Chapter In Context

Matter exists in three main physical states under conditions we encounter in everyday life: gaseous, liquid, and solid. Of these, the most fluid and easily changed is the gaseous state. Gases differ significantly from liquids and solids in that both liquids and solids are condensed states with molecules packed close to one another, whereas gases have molecules spaced far apart. This chapter examines the bulk properties of gases and the molecular scale interpretation of those properties.

10.1 Properties of Gases



OWL Opening Exploration
10.X

Gases are one of the three major states of matter, and differ from liquids and solids more than they differ from each other.

	Solid	Liquid	Gas
Density	High	High	Low
Compressible	No	No	Yes
Fluid	No	Yes	Yes

The most striking property of gases is the simple relationship between the pressure, volume and temperature of a gas and how a change in one of these properties affects the other properties. For example, if you decrease the volume of a gas sample, the gas pressure will increase and often its temperature will rise. The same simple relationship does not exist for solids or liquids. The major properties of gases are given in Table 10.1

Table 10.1: Properties of Gases and their Common Units

Property	Common Unit	Other Units	Symbol
Mass	grams, g	mg, kg	-
Amount	moles, mol	none	n
Volume	liters, L	mL	V
Pressure	atmosphere, atm	bar, mm Hg, psi, kPa	P
Temperature	Kelvin, K	°C, °F	T

Pressure

Gases exert pressure on surfaces, measured as a force exerted on a given area of surface. A confined gas exerts pressure on the interior walls of the container holding it and the gases in our atmosphere exert pressure on every surface with which they come in contact.

Gas pressure is commonly measured using a barometer. The first barometers consisted of a long, narrow tube that was sealed at one end, filled with liquid mercury, and then inverted into a pool of mercury (Figure 10.Xa). The gases in the atmosphere push down on the mercury in the pool and balance the weight of the mercury column in the tube. The higher the atmospheric pressure, the higher the column of mercury in the tube. The height of the mercury column, when measured in millimeters, gives the atmospheric pressure in units of mm Hg.

Pressure of a gas sample in the laboratory is measured with a manometer, which is shown in Figure 10.1b. In this case, mercury is added to a u-shaped tube. One end of the tube is connected to the gas sample under study. The other is open to the atmosphere. If the pressure of the gas sample is equal to atmospheric pressure, the height of the mercury is the same on both sides of the tube. In figure 10.1b, the pressure of the gas is greater than atmospheric pressure by “h” mm Hg.

$$\text{Pressure} = \frac{\text{force}}{\text{area}}$$

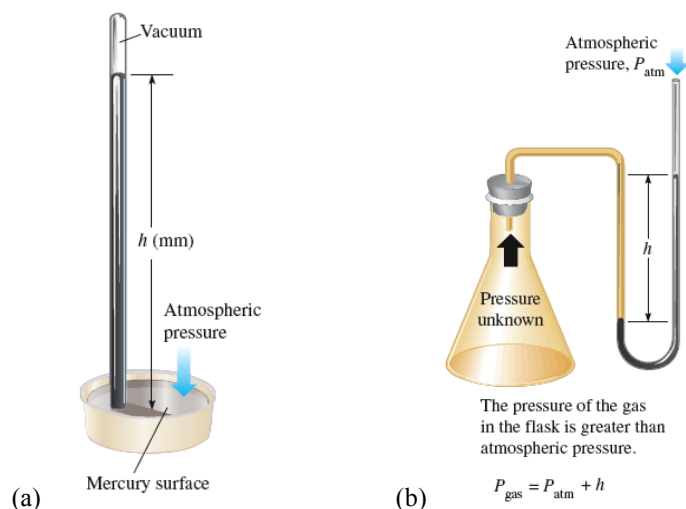

Figure 10.X(a) A barometer for measuring atmospheric pressure
(b) A manometer for measuring the pressure of a gas sample

Gas pressure is expressed in different units. The English pressure unit, pounds per square inch (psi), is a measure of how many pounds of force a gas exerts on one square inch of a surface. Atmospheric pressure at sea level is approximately 14.7 psi. This means that an 8½ by 11 inch piece of paper has a total force on it of over 1370 pounds. Commonly used pressure units are given in Table 10.2. Early pressure units were based on pressure measurements at sea level, where on average the mercury column has a height of 760 mm. This measurement was used to define the standard atmosphere (1 atm = 760 mm Hg). Modern scientific studies generally use gas pressure units of bar (the SI unit for pressure), mm Hg and atm.

Table 10.2 Common Units of Gas Pressure

1 atm	= 1.013 bar	(bar)
	= 101.3 kPa	(kilopascal)
	= 760 torr	(torr)
	= 760 mm Hg	(millimeters of mercury)
	= 14.7 psi	(pounds per square inch)

EXAMPLE PROBLEM: Pressure Units

A gas sample has a pressure of 722 mmHg. What is this pressure in atmospheres?

SOLUTION:

Use the relationship 1 atm = 760 mm Hg to convert between these pressure units.

$$722 \text{ mm Hg} \times \frac{1 \text{ atm}}{760 \text{ mm Hg}} = 0.950 \text{ atm}$$



OWL Example Problems
 10.2 Pressure Units

10.2 Historical Gas Laws



OWL Opening Exploration
10.3 Gas Laws: Simulation

Gases were the basis for some of the first scientific studies that attempted to model the behavior of matter mathematically. That is, gases can be described by relatively simple mathematical relationships. Today, these relationships are well accepted and collectively called the gas laws.

Gas Law	Properties Related	Equation
Boyle's Law	Pressure and Volume	$P \times V = c_B$ (at constant T and n)
Charles's Law	Temperature and Volume	$V = c_C \times T$ (at constant P and n)
Avogadro's Law	Amount and Volume	$V = c_A \times n$ (at constant P and T)

where c_B , c_C , and c_A are constants that vary with experiments

Boyle's Law $P \times V = c_B$

Boyle's law states that the pressure and volume of a gas sample are inversely related when the amount of gas and temperature are held constant. For example, consider a syringe that is filled with a sample of a gas and attached to a pressure gauge and a temperature control unit. When the plunger is depressed (decreasing the volume of the gas sample), the pressure of the gas increases (Figure 10.x).

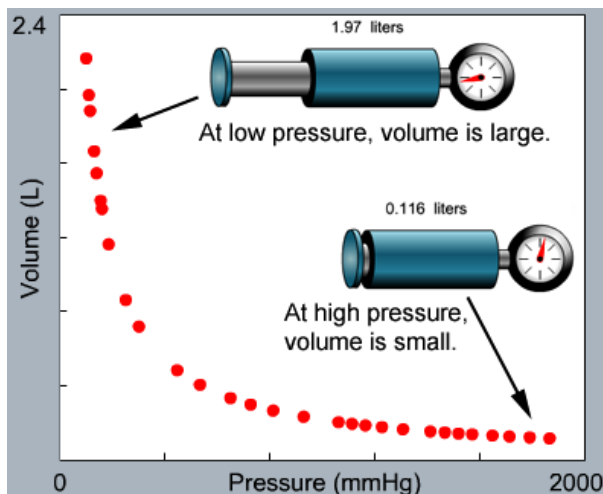

Figure 10.X. Volume changes upon applying pressure to a gas-filled syringe. Temperature is constant and no gas escapes from the syringe.

When the pressure on the syringe is low, the gas sample has a large volume. When the pressure is high, the gas is compressed and the volume is smaller. The relationship between pressure and volume is therefore an inverse one:

$$\text{volume} \propto \frac{1}{\text{pressure}} \quad \text{or} \quad P \times V = c_B$$

Because the product of gas pressure and volume is a constant (when temperature and amount of gas are held constant), it is possible to calculate the new pressure or volume of a gas sample when one of the properties is changed.

$$P_1 \times V_1 = P_2 \times V_2 \quad (10.x)$$

The subscripts "1" and "2" indicate the different experimental conditions before and after volume or temperature is changed.

EXAMPLE PROBLEM: Boyle's Law

A sample of gas has a volume of 458 mL at a pressure of 0.970 atm. The gas is compressed and now has a pressure of 3.20 atm. Predict if the new volume is greater or less than the initial volume, and calculate the new volume. Assume temperature is constant and no gas escaped from the container.

SOLUTION:

According to Boyle's law, pressure and volume are inversely related when the temperature and amount of gas are held constant. In this case, the pressure increases from 0.970 atm to 3.20 atm, so the new volume should decrease. It will be less than the original volume.

To calculate the new volume, first make a table of the known and unknown pressure and volume data. In this case, the initial volume and pressure and the new pressure are known and the new volume must be calculated.

$$P_1 = 0.970 \text{ atm}$$

$$P_2 = 3.20 \text{ atm}$$

$$V_1 = 458 \text{ mL}$$

$$V_2 = ?$$

Rearrange Boyle's law to solve for V_2 and calculate the new volume of the gas sample.

$$V_2 = \frac{P_1 \times V_1}{P_2} = \frac{(0.970 \text{ atm})(458 \text{ mL})}{3.20 \text{ atm}} = 139 \text{ mL}$$

The pressure units (atm) cancel, leaving volume in units of mL. Notice that the final volume is less than the initial volume, as we predicted.



OWL Example Problems
10.4 Boyle's Law

Charles's Law

$$V = c_c \times T$$

Charles's law states that the temperature and volume of a gas sample are directly related when the pressure and the amount of gas are held constant. For example, heating the air in a hot air balloon causes it to expand, filling the balloon. Consider a sample of gas held in a syringe attached to a pressure gauge and a temperature control unit (Figure 10.X).

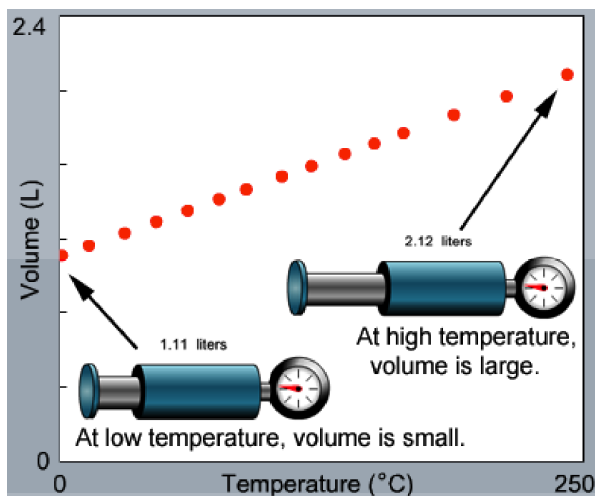

Figure 10.X. Volume changes upon changing the temperature of a gas sample. The pressure is held constant and no gas escapes the syringe.

When the pressure and amount of gas is held constant, decreasing the temperature of the gas sample decreases the volume of the gas. The two properties are directly related.

$$V = c_c \times T$$

Because the ratio of gas volume and temperature (in Kelvin units) is a constant (when pressure and amount of gas are held constant), it is possible to calculate the new volume or temperature of a gas sample when one of the properties is changed.

$$\frac{V_1}{T_1} = \frac{V_2}{T_2} \quad (10.x)$$

The subscripts “1” and “2” indicate the different experimental conditions before and after volume or temperature is changed.

EXAMPLE PROBLEM: Charles's Law

A sample of gas has a volume of 2.48 L at a temperature of 58.0 °C. The gas sample is cooled to a temperature of -5.00 °C (assume pressure and amount of gas are held constant). Predict if the new volume is greater or less than the original volume, and calculate the new volume.

SOLUTION:

According to Charles's law, temperature and volume are directly related when the pressure and amount of gas are held constant. In this case, the temperature decreases from 58.00 °C to -5.00 °C, so the volume should also decrease. It will be less than the original volume.

To calculate the new volume, first make a table of the known and unknown volume and temperature data. In this case, the initial volume and temperature and the new temperature are known and the new volume must be calculated. Note that all temperature data must be in Kelvin temperature units.

$$V_1 = 2.48 \text{ L}$$

$$V_2 = ?$$

$$T_1 = 58.00 \text{ °C} + 273.15 = 331.15 \text{ K}$$

$$T_2 = -5.00 \text{ °C} + 273.15 = 268.15 \text{ K}$$

Rearrange Charles's law to solve for V_2 and calculate the new volume of the gas sample.

$$V_2 = \frac{V_1 \times T_2}{T_1} = \frac{(2.48 \text{ L})(268.15 \text{ K})}{331.15 \text{ K}} = 2.01 \text{ L}$$

The temperature units (J) cancel, leaving volume in units of L. Notice that the final volume is less than the initial volume, as we predicted.



OWL Example Problems
10.5 Charles's Law

As shown in the previous example, decreasing the temperature of a gas sample (at constant pressure and amount of gas) results in a decrease in the gas volume. A plot of temperature and volume data for a sample of gas is shown in Figure 10.X. Extending the plot to the point at which the gas volume is equal to zero shows that this occurs at a temperature of -273.15 °C. This temperature is known as absolute zero, or 0 K.

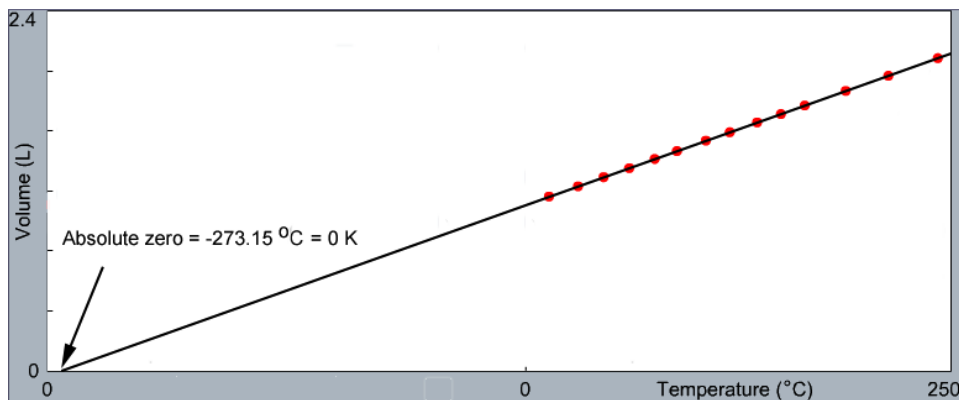

Figure 10.4. An extended Charles's law plot.

Avogadro's Law

$$V = c_A \times n$$

Avogadro's hypothesis states that equal volumes of gases have the same number of particles when they are at the same temperature and pressure. One aspect of the hypothesis is called **Avogadro's law**, which states that the volume and amount (moles) of a gas are directly related when pressure and temperature are held constant. Consider two syringes that hold different amounts of the same gas, with each syringe attached to a pressure gauge and a temperature control unit (Figure 10.X).

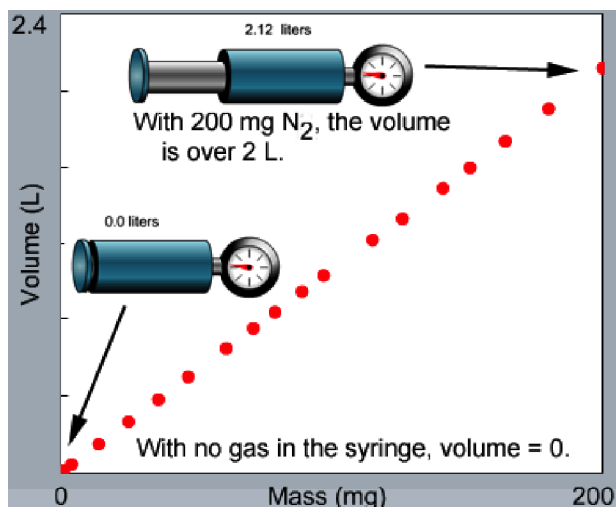

Figure 10.X. Plot of volume of samples of N_2 gas with differing amounts of N_2 present. The temperature and pressure does not change between samples.

As the amount of gas in the syringe is increased (at constant temperature and pressure), the volume of the gas increases.

$$V = c_A \times n$$

Avogadro's law can also be used to calculate the new volume or amount of a gas sample when one of the properties is changed.

$$\frac{V_1}{n_1} = \frac{V_2}{n_2} \quad (10.x)$$

The subscripts "1" and "2" indicate the different experimental conditions before and after volume or temperature is changed.

Avogadro's law is independent of the identity of the gas, as shown in a plot of volume vs. amount of gas (Figure 10.Xa). This means that a 1 mole sample of Xe has the same volume as a 1 mole sample of N_2 (at the same temperature and pressure), even though the Xe sample has a mass over 4.5 times as great. The same is not true for gas samples with equal mass, as shown in Figure 10.Xb.

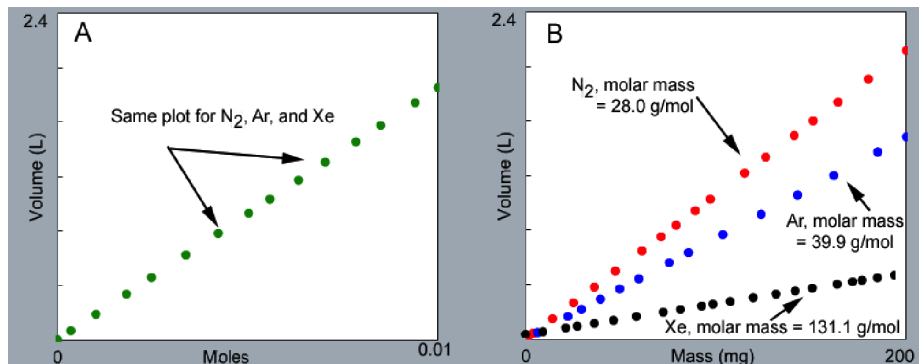

Figure 10.X. Volume vs. mass and Avogadro's law plots for N_2 , Ar, and Xe

EXAMPLE PROBLEM: Avogadro's Law

A sample of gas contains 2.4 mol of SO₂ and 1.2 mol O₂, and occupies a volume of 17.9 L. The following reaction takes place: $2 \text{SO}_2(\text{g}) + \text{O}_2 \rightarrow 2 \text{SO}_3$

Calculate the volume of the sample after the reaction takes place (assume temperature and pressure are constant).

SOLUTION:

Make a table of the known and unknown volume and temperature data. In this case, the initial volume and amount of reactants and the amounts of product are known and the new volume must be calculated.

$$V_1 = 17.9 \text{ L}$$

$$V_2 = ?$$

$$n_1 = 3.6 \text{ mol SO}_2 \text{ and O}_2$$

$$n_2 = 2.4 \text{ mol SO}_3$$

The reactants are present in a 2:1 stoichiometric ratio, so they are consumed completely upon reaction to form SO₃.

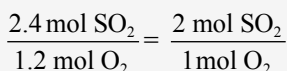

Use the balanced equation to calculate the amount of SO₃ produced.

$$2.4 \text{ mol SO}_2 \times \frac{2 \text{ mol SO}_3}{2 \text{ mol SO}_2} = 2.4 \text{ mol SO}_3$$

Rearrange Avogadro's law to solve for V₂ and calculate the volume of the gas sample after the reaction is complete.

$$V_2 = \frac{V_1 \times n_2}{n_1} = \frac{(17.9 \text{ L})(2.4 \text{ mol})}{3.6 \text{ mol}} = 11.9 \text{ L}$$

Notice that the new volume is smaller than the initial volume, which makes sense because the amount of gas decreased as a result of the chemical reaction.



OWL Example Problems
10.6 Avogadro's Law

10.3 The Ideal and Combined Gas Laws



OWL Opening Exploration
10.7 Gas Density: Simulation

The three historical gas laws, rewritten solved for volume,

Boyle's Law: $V = c_B \times \frac{1}{P}$ (at constant T, n)

Charles's Law: $V = c_C \times T$ (at constant P, n)

Avogadro's Law: $V = c_A \times n$ (at constant P, T)

can be combined into a single equation that relates volume, pressure, temperature, and the amount of any gas.

$$V = \text{constant} \times \frac{nT}{P} \quad \text{or} \quad \frac{PV}{nT} = \text{constant}$$

This is the **ideal gas law**, where the constant is given the symbol R and called the universal gas constant or the ideal gas constant ($R = 0.082057 \text{ L}\cdot\text{atm}/\text{K}\cdot\text{mol}$).

$$PV = nRT \quad (10.x)$$

One property of an **ideal gas** is that it follows the ideal gas law; that is, its variables (P, V, n, and T) vary according to the ideal gas law.

Because the ratio involving pressure, volume, amount, and temperature of a gas is a constant, it can be used in the form of the **combined gas law** to calculate the new

The universal gas constant is independent of the identity of the gas. The units of R (L·atm/K·mol) control the units of P, V, T, and n in any equation that includes this constant.

pressure, volume, amount, or temperature of a gas when one or more of these properties is changed.

$$\frac{P_1 V_1}{n_1 T_1} = \frac{P_2 V_2}{n_2 T_2} \quad (10.x)$$

Using the Combined Gas Law

The combined gas law is most often used to calculate the new pressure, volume, or temperature of a gas sample when two of these properties are changed. Under typical conditions, the amount of the gas is held constant and $n_1 = n_2$.

EXAMPLE PROBLEM: The Combined Gas Law

A 2.68-L sample of gas has a pressure of 1.22 atm and a temperature of 29 °C. The sample is compressed to a volume of 1.41 L and cooled to -17 °C. Calculate the new pressure of the gas, assuming that no gas escaped during the experiment.

SOLUTION:

Make a table of the known and unknown pressure, volume, and temperature data. Note that temperature must be converted to Kelvin temperature units and that the amount of gas (n) does not change.

$$\begin{array}{ll} P_1 = 1.22 \text{ atm} & P_2 = ? \\ V_1 = 2.68 \text{ L} & V_2 = 1.41 \text{ L} \\ T_1 = 29 \text{ }^\circ\text{C} + 273 = 302 \text{ K} & T_2 = -17 \text{ }^\circ\text{C} + 273 = 256 \text{ K} \\ n_1 = n_2 & \end{array}$$

Rearrange the combined gas law to solve for P_2 and calculate the new pressure of the gas sample.

$$P_2 = \frac{P_1 \times V_1 \times T_2}{V_2 \times T_1} = \frac{(1.22 \text{ atm})(2.68 \text{ L})(256 \text{ K})}{(1.41 \text{ L})(302 \text{ K})} = 1.97 \text{ atm}$$



OWL Example Problems
10.8 The Combined Gas Law

Using the Ideal Gas Law to Calculate Gas Properties

When three of the four properties of a gas sample are known, the ideal gas law can be used to calculate the unknown property.

EXAMPLE PROBLEM: The Ideal Gas Law

A sample of O_2 gas has a volume of 255 mL, a pressure of 742 mm Hg, and is at a temperature of 19.6 °C. Calculate the amount of O_2 in the gas sample.

SOLUTION:

The ideal gas law contains a constant ($R = 0.082057 \text{ L}\cdot\text{atm}/\text{K}\cdot\text{mol}$), so all properties must have units that match those in the constant.

$$P = 742 \text{ mm Hg} \times \frac{1 \text{ atm}}{760 \text{ mm Hg}} = 0.976 \text{ atm}$$

$$V = 255 \text{ mL} \times \frac{1 \text{ L}}{1000 \text{ mL}} = 0.255 \text{ L}$$

$$T = (19.6 + 273.15) \text{ K} = 292.8 \text{ K}$$

$$n = ?$$

Rearrange the ideal gas law to solve for n and calculate the amount of oxygen in the sample.

$$n_{O_2} = \frac{PV}{RT} = \frac{(0.976 \text{ atm})(0.255 \text{ L})}{(0.082057 \text{ L}\cdot\text{atm}/\text{K}\cdot\text{mol})(292.8 \text{ K})} = 0.0104 \text{ mol}$$



OWL Example Problems
10.9 The Ideal Gas Law: Tutor
10.10 The Ideal Gas Law

Using the Ideal Gas Law to Calculate Molar Mass and Density

If a compound exists in gaseous form at some temperature, it is very easy (and relatively inexpensive) to determine its molar mass from simple laboratory experiments. Molar mass can be calculated from pressure, temperature, and density measurements and the use of the ideal gas law. Because molar mass is defined as

$$\text{molar mass } (M) = \frac{m \text{ (mass, in g)}}{n \text{ (amount, in mol)}}$$

the relationship $n = \frac{m}{M}$ can be substituted into the ideal gas law.

$$PV = \left(\frac{m}{M} \right) RT$$

Rearranging this equation,

$$M = \frac{mRT}{PV} = \left(\frac{m}{V} \right) \frac{RT}{P}$$

or

$$M = \frac{dRT}{P} \quad (10.x)$$

where M = molar mass (g/mol) and d = gas density (g/L). This form of the ideal gas law can be used to calculate the molar mass or density of a gas, as shown in the following examples.

EXAMPLE PROBLEM: The Ideal Gas Law and Molar Mass

A 4.07-g sample of an unknown gas has a volume of 876 mL and a pressure of 737 mmHg at 30.4 °C. Calculate the molar mass of this compound.

SOLUTION:

There are two ways to solve this problem, using Equation 10.x or the ideal gas law in its original form. Note that both of these equations contain a constant ($R = 0.082057 \text{ L}\cdot\text{atm}/\text{K}\cdot\text{mol}$), so all properties must have units that match those in the constant.

Method 1:

$$P = 737 \text{ mm Hg} \times \frac{1 \text{ atm}}{760 \text{ mm Hg}} = 0.970 \text{ atm}$$

$$T = (30.4 + 273.15) \text{ K} = 303.6 \text{ K}$$

$$V = 876 \text{ mL} \times \frac{1 \text{ L}}{1000 \text{ mL}} = 0.876 \text{ L}$$

$$d = \frac{4.07 \text{ g}}{0.876 \text{ L}} = 4.65 \text{ g/L}$$

Use equation 10.x to calculate the molar mass of the unknown gas.

$$M = \frac{dRT}{P} = \frac{(4.65 \text{ g/L})(0.082057 \text{ L}\cdot\text{atm}/\text{K}\cdot\text{mol})(303.6 \text{ K})}{0.970 \text{ atm}} = 119 \text{ g/mol}$$

Method 2:

Rearrange the ideal gas law to calculate the amount (n) of gas present.

$$n = \frac{PV}{RT} = \frac{(0.970 \text{ atm})(0.876 \text{ L})}{(0.082057 \text{ L}\cdot\text{atm}/\text{K}\cdot\text{mol})(303.6 \text{ K})} = 0.0341 \text{ mol}$$

$$M = \frac{4.07 \text{ g}}{0.0341 \text{ mol}} = 119 \text{ g/mol}$$



OWL Example Problems

10.11 The Ideal Gas Law and Molar Mass 1: Tutor

10.12 The Ideal Gas Law and Molar Mass 2: Tutor

10.13 The Ideal Gas Law and Molar Mass

EXAMPLE PROBLEM: The Ideal Gas Law and Density

Calculate the density of oxygen gas at 788 mm Hg and 22.5 °C.

SOLUTION:

Equation 10.x contains a constant ($R = 0.082057 \text{ L}\cdot\text{atm}/\text{K}\cdot\text{mol}$), so all properties must have units that match those in the constant.

$$P = 788 \text{ mm Hg} \times \frac{1 \text{ atm}}{760 \text{ mm Hg}} = 1.04 \text{ atm}$$

$$T = (22.5 + 273.15) \text{ K} = 295.7 \text{ K}$$

$$M(\text{O}_2) = 32.00 \text{ g/mol}$$

Solve the equation for density and use it to calculate the density of oxygen under these conditions.

$$d = \frac{PM}{RT} = \frac{(1.04 \text{ atm})(32.00 \text{ g/mol})}{(0.082057 \text{ L}\cdot\text{atm}/\text{K}\cdot\text{mol})(295.7 \text{ K})} = 1.37 \text{ g/L}$$



OWL Example Problems

10.14 The Ideal Gas Law and Density

Gas densities are often reported under a set of standard temperature and pressure conditions (STP) of 1.00 atm and 273.15 K (0 °C). Under these conditions, 1 mole of an ideal gas has a standard molar volume of 22.4 L.

$$V = \frac{nRT}{P} = \frac{(1 \text{ mol})(0.082057 \text{ L}\cdot\text{atm}/\text{K}\cdot\text{mol})(273.15 \text{ K})}{1.00 \text{ atm}} = 22.4 \text{ L at STP}$$

The relationship between gas density and molar mass is shown in Table 10.X, which contains gas densities at STP for some common and industrially important gases.

Table 10.X: Gas Densities at STP

Gas	Molar Mass(g/mol)	Density at STP (g/L)
H ₂	2.02	0.0892
He	4.00	0.178
N ₂	28.00	1.25
CO	28.01	1.25
O ₂	32.00	1.42
CO ₂	44.01	1.96
propane (C ₃ H ₈)	44.09	1.97
butane (C ₄ H ₁₀)	58.12	2.59
UF ₆	351.99	15.69

Notice that some flammable gases such as propane and butane are more dense than either O₂ or N₂. This means that these gases sink in air and will collect near the ground, so places where these gases might leak (such as in a recreational vehicle) will have a gas detector mounted near the floor. Carbon monoxide has a density very similar to that of O₂ and N₂ so it mixes well with these gases. For this reason, CO detectors can be placed anywhere on a wall (and are usually found mounted higher on the wall of a recreational vehicle).

Standard conditions vs. standard state

Note that the temperature used for standard conditions (STP, 0 °C) is not the temperature typically used for standard state conditions (25 °C).

10.4 Dalton's Law of Partial Pressures



OWL Opening Exploration
10.X

Our atmosphere is a mixture of many gases and this mixture changes composition constantly. For example, every time you breathe in and out, you make small changes to the amount of oxygen, carbon dioxide, and water in the air around you. **Dalton's Law of Partial Pressures** states that the pressure of a gas mixture is equal to the sum of the pressures due to the individual gases of the sample, called partial pressures. For a mixture containing the gases A, B, and C, for example,

$$P_{\text{total}} = P_A + P_B + P_C \quad (10.x)$$

where P_{total} is the pressure of the mixture and P_X is the partial pressure of gas X in the mixture. Each gas in a mixture behaves as an ideal gas and as if it alone occupies the container. This means that while individual partial pressures may differ, all gases in the mixture have the same volume (equal to the container volume) and temperature.

EXAMPLE PROBLEM: Dalton's Law of Partial Pressures

A gas mixture is made up of O_2 (0.136 g), CO_2 (0.230 g), and Xe (1.35 g). The mixture has a volume of 1.82 L at 22.0 °C. Calculate the partial pressure of each gas in the mixture and the total pressure of the gas mixture.

SOLUTION:

The partial pressure of each gas is calculated from the ideal gas equation.

$$P_{\text{O}_2} = \frac{nRT}{V} = \frac{\left(0.136 \text{ g} \times \frac{1 \text{ mol O}_2}{32.00 \text{ g}}\right)(0.082057 \text{ L}\cdot\text{atm}/\text{K}\cdot\text{mol})(22.0 + 273.15 \text{ K})}{1.82 \text{ L}} = 0.0566 \text{ atm}$$

$$P_{\text{CO}_2} = \frac{nRT}{V} = \frac{\left(0.230 \text{ g} \times \frac{1 \text{ mol CO}_2}{44.01 \text{ g}}\right)(0.082057 \text{ L}\cdot\text{atm}/\text{K}\cdot\text{mol})(22.0 + 273.15 \text{ K})}{1.82 \text{ L}} = 0.0695 \text{ atm}$$

$$P_{\text{Xe}} = \frac{nRT}{V} = \frac{\left(1.35 \text{ g} \times \frac{1 \text{ mol Xe}}{131.3 \text{ g}}\right)(0.082057 \text{ L}\cdot\text{atm}/\text{K}\cdot\text{mol})(22.0 + 273.15 \text{ K})}{1.82 \text{ L}} = 0.137 \text{ atm}$$

Notice that the three gases have the same volume and temperature but different pressures.

The total pressure is the sum of the partial pressures for the gases in the mixture.

$$P_{\text{total}} = P_{\text{O}_2} + P_{\text{CO}_2} + P_{\text{Xe}} = 0.0566 \text{ atm} + 0.0695 \text{ atm} + 0.137 \text{ atm} = 0.263 \text{ atm}$$



OWL Example Problems
10.16 Dalton's Law of Partial Pressures: Tutor
10.17 Dalton's Law of Partial Pressures

A common laboratory experiment involves collecting the gas generated during a chemical reaction by water displacement (Figure 10.x). Because water can exist in gaseous form (as water vapor), the gas that is collected is a mixture of both the gas formed during the chemical reaction and water vapor.



Figure 10.X. Collecting a gas by water displacement

According to Dalton's Law of Partial Pressures, the pressure of the collected gas mixture is equal to the partial pressure of the gas formed during the chemical reaction plus the partial pressure of the water vapor.

$$P_{\text{total}} = P_{\text{gas}} + P_{\text{H}_2\text{O}}$$

Water vapor pressure varies with temperature. Table 10.X shows vapor pressure values for moderate temperatures; a more complete table is found in the appendix of this textbook.

Table 10.X Vapor Pressure of Water

Temperature (°C)	Vapor Pressure of Water mmHg
19	16.48
20	17.54
21	18.65
22	19.83
23	21.07
24	22.38
25	23.76
26	25.21
27	26.74
28	28.35

EXAMPLE PROBLEM: Collecting a Gas over Water

Aluminum reacts with strong acids such as HCl to form hydrogen gas.

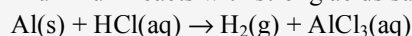

In one experiment, 0.0297-g sample of Al reacts with excess 6 M HCl and the gas produced is collected by water displacement. The gas sample has a temperature of 22.0 °C and a volume of 27.58 mL, and a pressure of 738 mm Hg. Calculate the amount of gas produced in the reaction.

SOLUTION:

The gas is a mixture containing water vapor, which has a vapor pressure of 19.83 mm Hg at 22.0 °C (Table 10.X). Subtract the water vapor pressure from the total pressure of the mixture to calculate the partial pressure of the other gas in the mixture.

$$P_{\text{gas}} = P_{\text{total}} - P_{\text{H}_2\text{O}} = 738 \text{ mm Hg} - 19.83 \text{ mm Hg} = 718 \text{ mm Hg}$$

Use the ideal gas law to calculate the amount of gas produced in the reaction.

$$P = 718 \text{ mm Hg} \times \frac{1 \text{ atm}}{760 \text{ mm Hg}} = 0.945 \text{ atm}$$

$$V = 27.58 \text{ mL} \times \frac{1 \text{ L}}{1000 \text{ mL}} = 0.02758 \text{ L}$$

$$T = (22.0 + 273.15) \text{ K} = 295.2 \text{ K}$$

$$n_{\text{H}_2} = \frac{PV}{RT} = \frac{(0.945 \text{ atm})(0.02758 \text{ L})}{(0.082057 \text{ L}\cdot\text{atm}/\text{K}\cdot\text{mol})(295.2 \text{ K})} = 1.08 \times 10^{-3} \text{ mol}$$



OWL Example Problems
10.18 Collecting a Gas over Water

Partial Pressure and Mole Fractions of Gases

Within a gas mixture, the total pressure is the sum of the partial pressures of each of the component gases. The ideal gas law shows that pressure and amount (moles) of any gas are directly related.

$$P = n \cdot \frac{RT}{V}$$

Therefore, the degree to which any one gas contributes to the total pressure is directly related to the amount (moles) of that gas present in a mixture. In other words, the greater the amount of a gas in a mixture, the greater its partial pressure and the greater amount its partial pressure contributes to the total pressure. Quantitatively, this relationship is shown below, where P_A and n_A are the partial pressure and amount (moles), respectively, of gas A in a mixture of gases, and n_{total} is the total amount (moles) of gas in the mixture:

$$\frac{P_A}{P_{\text{total}}} = \frac{n_A}{n_{\text{total}}} \quad (10.x)$$

The ratio n_A/n_{total} is the **mole fraction** of gas A in a mixture of gases, and it is given the symbol χ_A . Rearranging equation 10.x to solve for the partial pressure of gas A,

$$P_A = P_{\text{total}} \cdot \chi_A \quad (10.x)$$

Note that mole fraction is a unitless quantity. Also, the sum of the mole fractions for all gases in a mixture is equal to 1. For a mixture containing gases A, B, and C, for example,

$$\chi_A + \chi_B + \chi_C = 1 \quad (10.x)$$

EXAMPLE PROBLEM: Partial Pressures and Mole Fraction

A gas mixture contains the noble gases Ne, Ar, and Kr. The total pressure of the mixture is 2.46 atm, and the partial pressure of Ar is 1.44 atm. If a total of 18.0 mol of gas are present, what amount of Ar is present?

SOLUTION:

The amount (moles) of Ar is equal to the total moles of gas in the mixture times its mole fraction. The first step, then, is to determine the mole fraction of Ar in the mixture. Solving equation 10.x for mole fraction of Ar,

$$\chi_{\text{Ar}} = \frac{P_{\text{Ar}}}{P_{\text{total}}} = \frac{1.44 \text{ atm}}{2.46 \text{ atm}} = 0.585$$

Use the mole fraction of Ar and the total amount of gases in the mixture to calculate moles of Ar in the mixture.

$$0.585 = \frac{n_{\text{Ar}}}{n_{\text{total}}} = \frac{n_{\text{Ar}}}{18.0 \text{ mol}}$$

$$n_{\text{Ar}} = 10.5 \text{ mol}$$



OWL Example Problems
10.X

10.5 Gas Laws and Stoichiometry



OWL Opening Exploration
10.X

We investigated stoichiometric relationships for systems involving pure substances and solutions in Chapters 3 and 4, where the amount of a reactant or product was determined from mass data or from volume and concentration data. We now have the tools needed to include the gas properties of pressure, temperature, and volume in the stoichiometric relationships derived in the earlier chapters, as shown schematically in Figure 10.X.

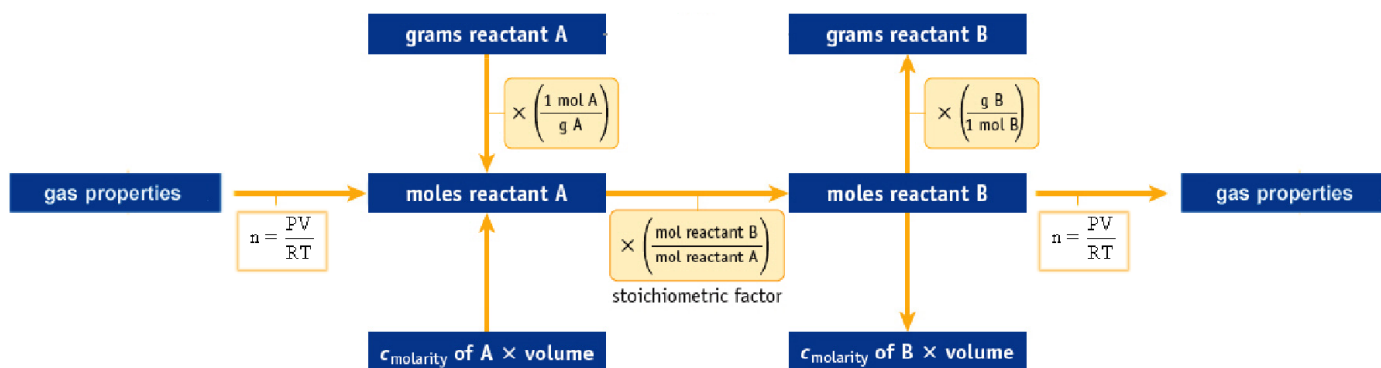
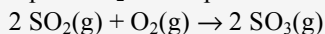

Figure 10.X. Schematic flow chart of stoichiometric relationships

EXAMPLE PROBLEM: Gas Laws and Stoichiometry

A sample of O_2 with a pressure of 1.42 atm and a volume of 250. mL is allowed to react with excess SO_2 at $129^\circ C$.



Calculate the pressure of the SO_3 produced in the reaction if it is transferred to a 1.00-L flask and cooled to $35.0^\circ C$.

SOLUTION:

Step 1: Calculate the amount of reactant (O_2) available using the ideal gas law.

$$n_{O_2} = \frac{PV}{RT} = \frac{(1.42 \text{ atm})(0.250 \text{ L})}{(0.082057 \text{ L}\cdot\text{atm}/\text{K}\cdot\text{mol})(129 + 273.15 \text{ K})} = 0.0108 \text{ mol}$$

Step 2: Use the amount of limiting reactant (O_2) and the balanced equation to calculate the amount of SO_3 produced.

$$0.0108 \text{ mol } O_2 \times \frac{2 \text{ mol } SO_3}{1 \text{ mol } O_2} = 0.0216 \text{ mol } SO_3$$

Step 3: Use the ideal gas law and the new volume and temperature conditions to calculate the pressure of SO_3 .

$$P_{SO_3} = \frac{nRT}{V} = \frac{(0.0216 \text{ mol } SO_3)(0.082057 \text{ L}\cdot\text{atm}/\text{K}\cdot\text{mol})(35.0 + 273.15 \text{ K})}{1.00 \text{ L}} = 0.546 \text{ atm}$$



OWL Example Problems
10.20 Gas Laws and Stoichiometry: Tutor
10.21 Gas Laws and Stoichiometry
10.22 Partial Pressures and Stoichiometry: Tutor

10.6 Kinetic Molecular Theory



OWL Opening Exploration
 10.23 Kinetic Molecular Theory: Simulation
 10.24 Boltzmann Distributions: Simulation

The ideal gas law is striking in that it is independent of the chemical nature or identity of the gas and is a good description of the behavior of most gases. This suggests that gases behave similarly at the molecular level, an model that is explained in the **kinetic molecular theory**. According to this theory,

- gases consist of molecules whose separation is much larger than the molecules themselves;
- the molecules of a gas are in continuous, random, and rapid motion;
- the average kinetic energy of gas molecules is determined by the gas temperature, and all gas molecules at the same temperature, regardless of mass, have the same average kinetic energy; and
- gas molecules collide with each other and with the walls of their container, but they do so without loss of energy in “perfectly elastic” collisions.

We can use this theory to better understand the historical gas laws and how gases behave at the molecular level.

Molecular Speed, Mass, and Temperature

Gas molecules move through space at very high speeds. As you saw in Chapter 5, the kinetic energy of a moving object is given by:

$$KE = \frac{1}{2}mv^2 \quad \text{where } m = \text{mass and } v = \text{velocity (speed)}$$

For a collection of gas molecules, the mean (average) kinetic energy is directly related to the average of the square of the gas velocity and it can be shown that it is also directly related to the absolute temperature of the gas (Equation 10.x).

$$\overline{KE} = \frac{1}{2}m\overline{v^2} = \frac{3}{2}RT \quad (10.x)$$

The average velocity is therefore inversely related to the mass of gas molecules and directly related to the temperature of the gas.

Boltzmann Distribution Plots

Of course, not all gas molecules are moving at the same speed. Just like people or cars, a collection of gas molecules shows a range of speeds. The distribution of speeds is called a **Boltzmann distribution**. Figure 10.X shows a Boltzmann distributions plot for O₂ at 25 °C. Each point in a Boltzmann distribution plot gives the number of gas molecules moving at a particular speed. This Boltzmann distribution for O₂ starts out with low numbers of molecules at low speeds, increases to a maximum at around 400 m/s and then decreases smoothly to very low numbers at about 1000 m/s. This means that in a sample of O₂ gas at 25 °C, very few O₂ molecules are moving slower than 100 m/s, many molecules are moving at speeds between 300-600 m/s, and very few molecules are moving faster than 900 m/s. The peak around 450 m/s indicates the most probable speed at which the molecules are moving at this temperature. It does not mean that most of the molecules are moving that speed.

Note that in this case we include monoatomic gaseous atoms in our definition of molecules.

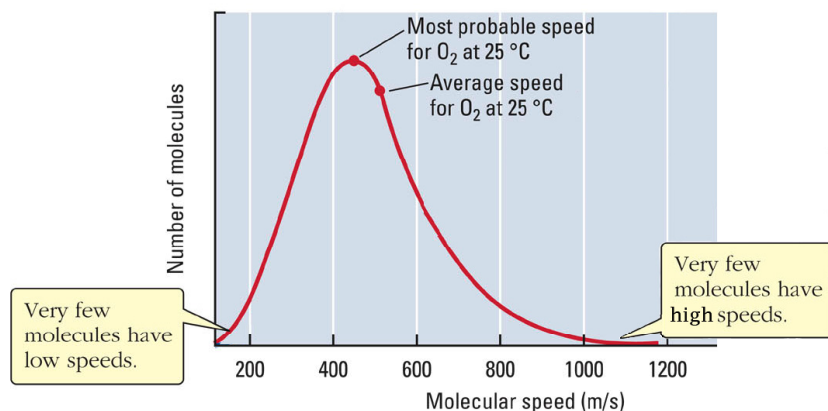
Figure 10.X. Boltzmann distribution plot for O_2 at $25\text{ }^\circ\text{C}$

Boltzmann distribution plots for a number of different gases, each at the same temperature, are shown in Figure 10.x.

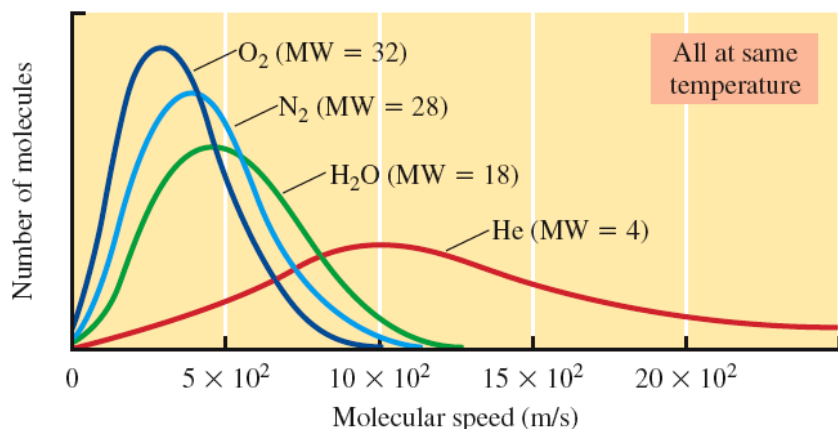
Figure 10.X. Boltzmann distribution plots for four different gases at $25\text{ }^\circ\text{C}$

The heights of the curves in this figure differ because the area under each curve represents the total number of molecules in the sample. In the case of O_2 , the gas molecules have a relatively narrow range of speeds, and therefore more molecules moving at any particular speed. Helium has a wide range of speeds, and therefore the curve is stretched out, with few molecules moving any particular speed.

Notice the relationship between the Boltzmann distribution plots and the molar mass of the gases in Figure 10.X. The peak in the O_2 curve is farthest to the left, and it therefore has the slowest moving molecules. The peak in the H_2O curve is farther to the right, so H_2O gas molecules move, on average, faster than O_2 molecules at the same temperature. The helium curve is shifted well to the right and has very fast moving molecules. Recall that average molecular speed depends on both the average kinetic energy and on the mass of the moving particles.

$$\overline{KE} = \frac{1}{2}m\overline{v^2} = \frac{3}{2}RT$$

According to the kinetic molecular theory, all gases at the same temperature have the same kinetic energy. Therefore, if a gas has a smaller mass, m , it must have a larger average velocity.

Molecular speed changes with temperature, as shown in Figure 10.x.

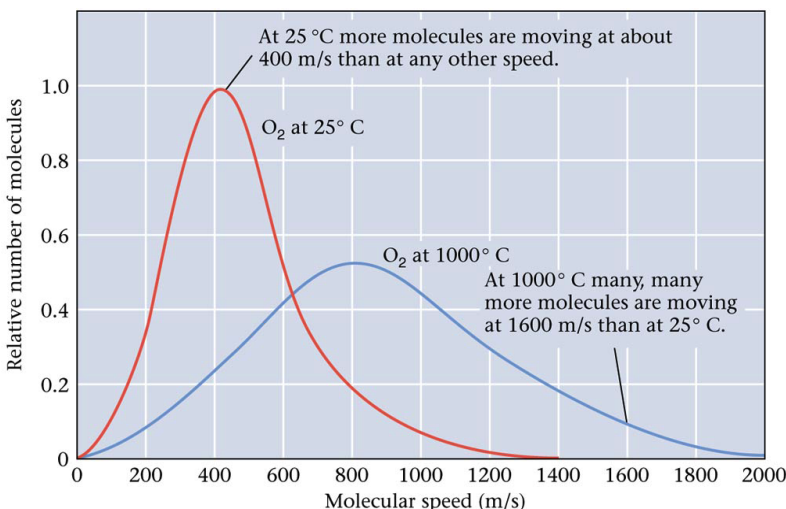

Figure 10.X. Boltzmann distribution plots for O_2 at $25^\circ C$ and $1000^\circ C$.

The curve for O_2 at the higher temperature is shifted to the right, indicating that O_2 molecules move faster, on average, at the higher temperature. Again consider the relationship between average molecular speed and kinetic energy.

$$\overline{KE} = \frac{1}{2} m \overline{v^2} = \frac{3}{2} RT$$

As the temperature increases, the average kinetic energy increases. Because the mass, m , is constant, as average kinetic energy, KE , increases, average molecular speed must increase.

In summary, Boltzmann distributions give us the following information:

1. Gases move with a range of speeds at a given temperature.
2. Gases move faster on average at higher temperatures.
3. Heavier gases move more slowly on average than lighter gases at the same temperature.



OWL Concept Exploration
10.25 Kinetic Molecular Theory – Qualitative

Relating the Kinetic Molecular Theory to the Gas Laws

For any theory to be recognized as useful, it must be consistent with experimental observations. The kinetic molecular theory therefore must be consistent with and help explain the well known gas laws. At the molecular level, the concept of pressure is considered in terms of collisions between gas molecules and the inside walls of a container. Each collision between a moving gas molecule and the static wall involves the imparting of a force pushing on the inside of the wall. The more collisions there are, and the more energetic the collisions on average, the greater the force and the higher the pressure.

P and n

Consider the relationship between pressure and moles of gas (assuming volume and temperature are constant). The general gas law predicts that pressure (P) is directly proportional to the moles of gas (n) present. The kinetic molecular theory explains this relationship. If the number of gas molecules inside a container is doubled, the number of molecule-wall collisions will exactly double. This means that twice as much force will push against the wall and the pressure is twice as great.

P and T

The relationship between temperature and pressure (assuming constant amount of gas and volume) can also be explained by the kinetic molecular theory. As the temperature of a gas in a container increases, the molecules move more rapidly. This does two things: it leads to more frequent collisions between the molecules and the walls of the container, and it also results in more energetic collisions between the molecules and container walls. Therefore, as temperature increases there are more frequent and energetic collisions on the inside of the walls and a greater pressure.

P and V

Finally, we can use the kinetic molecular theory to explain the inverse relationship between pressure and volume (assuming constant amount of gas and temperature). As the volume of a container is increased, the gas molecules take longer to move across the inside of the container before hitting the wall on the other side. This means that the frequency of collisions decrease, resulting in a lower pressure.

Root Mean Square Speed

The **root mean square (rms) speed** of a gas, depends on the temperature and molar mass of the gas.

$$v_{\text{rms}} = \sqrt{v^2} = \sqrt{\frac{3RT}{M}} \quad \text{where } R = 8.3145 \text{ J/K}\cdot\text{mol} \text{ and } M = \text{molar mass} \quad (10.x)$$

The constant R is the ideal gas constant expressed in thermodynamic units ($\text{J/K}\cdot\text{mol}$). Notice that the thermodynamic units of R require molar mass to be expressed in units of kg/mol when using this equation.

EXAMPLE PROBLEM: Root Mean Square Speed

Calculate the rms speed of NH_3 molecules at 21.5°C .

SOLUTION:

Use Equation 10.x, with molar mass in units of kg/mol .

$$v_{\text{rms}} = \sqrt{\frac{3RT}{M}} = \sqrt{\frac{3(8.3145 \text{ J/K}\cdot\text{mol})(21.5 + 273.15 \text{ K})}{0.01703 \text{ kg/mol}}} = 657 \text{ m/s}$$



OWL Example Problems
 10.26 Root Mean Square Speed: Tutor
 10.27 Root Mean Square Speed

Gas Diffusion and Effusion

As you saw in the previous example problem, an ammonia molecule moves with a root mean square speed of about 650 m/s at room temperature. This is the equivalent of almost 1500 miles per hour! If you open a bottle of ammonia, however, it can take minutes for the smell to travel across a room. Why do odors, which are the result of volatile molecules, take so long to travel? The answer lies in gas diffusion. As a gas molecule moves in an air-filled room, it is constantly colliding with other molecules that block its path. It therefore takes much more time for a gas sample to get from one place to another than it would if there were nothing in its way. This gas process is called **diffusion**, the mixing of gases, and is illustrated in Figure 10.X.

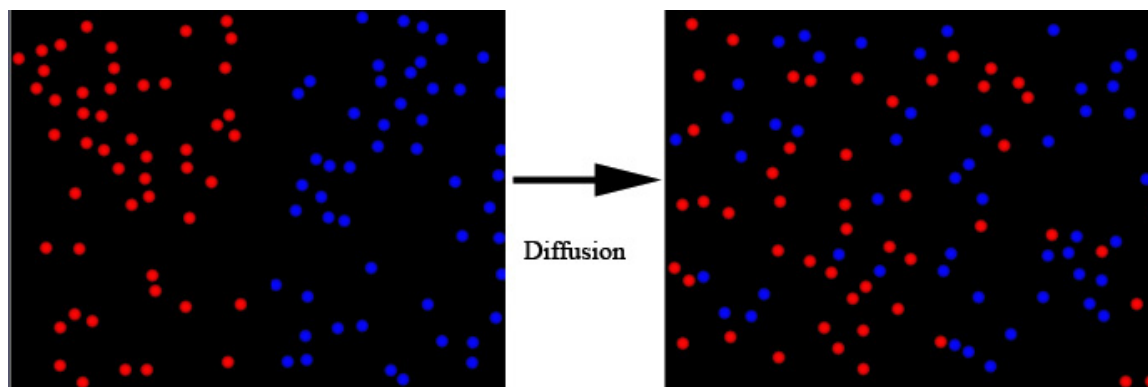

Figure 10.10. Gas Diffusion.

A process related to diffusion is **effusion**, the movement of gas molecules through a small opening into a vacuum (Figure 10.X).

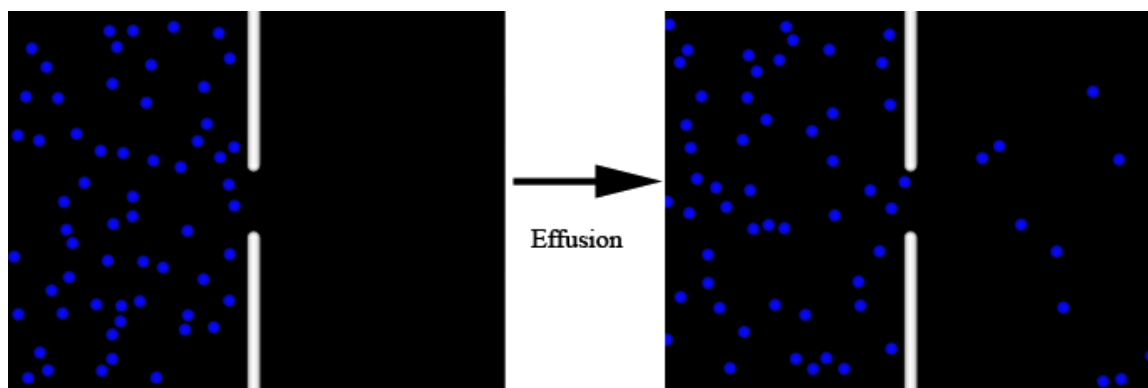

Figure 10.X Gas Effusion.

Graham's Law of Effusion states that the rate of effusion of a gas is inversely related to the square root of its molar mass. That is, lighter gases move faster and effuse more rapidly while heavier gases move more slowly and effuse more slowly.

$$\text{Rate of effusion} \propto \frac{1}{\sqrt{M}}$$

A useful form of Graham's Law is used to determine the molar mass of an unknown gas. The effusion rate of the unknown gas is compared to that of a gas with a known molar mass. The ratio of the effusion rates for the two gases is inversely related to the square root of the ratio of the molar masses.

$$\frac{\text{Rate}_1}{\text{Rate}_2} = \sqrt{\frac{M_2}{M_1}} \quad (10.x)$$

EXAMPLE PROBLEM: Graham's Law of Effusion

A sample of ethane, C_2H_6 , effuses through a small hole at a rate of 3.6×10^{-6} mol/hr. An unknown gas, under the same conditions, effuses at a rate of 1.3×10^{-6} mol/hr. Calculate the molar mass of the unknown gas.

SOLUTION:

Use Equation 10.x, and the molar mass of ethane to calculate the molar mass of the unknown gas.

$$\frac{\text{Rate}_1}{\text{Rate}_2} = \sqrt{\frac{M_2}{M_1}}$$

$$\frac{3.6 \times 10^{-6} \text{ mol/hr}}{1.3 \times 10^{-6} \text{ mol/hr}} = \sqrt{\frac{M_2}{30.07 \text{ g/mol}}}$$

$$M_2 = 230 \text{ g/mol}$$



OWL Example Problems
10.28 Effusion: Tutor
10.29 Effusion

10.7 Non-ideal Gases

OWL Opening Exploration
10.X

According to the Kinetic Molecular Theory, an ideal gas is assumed to experience only perfectly elastic collisions and take up no actual volume. So, although gas molecules have volume, it is assumed that each individual molecule occupies the entire volume of its container and that the other molecules do not take up any of the container volume.

At room temperature and pressures at or below 1 atm, most gases behave ideally. However, at high pressures or low temperatures, gases deviate from ideal behavior. For an ideal gas, the ratio PV/nRT is equal to 1 at any pressure. Therefore, one way to show deviation from ideal behavior is to plot the ratio PV/nRT as a function of pressure (Figure 10.x).

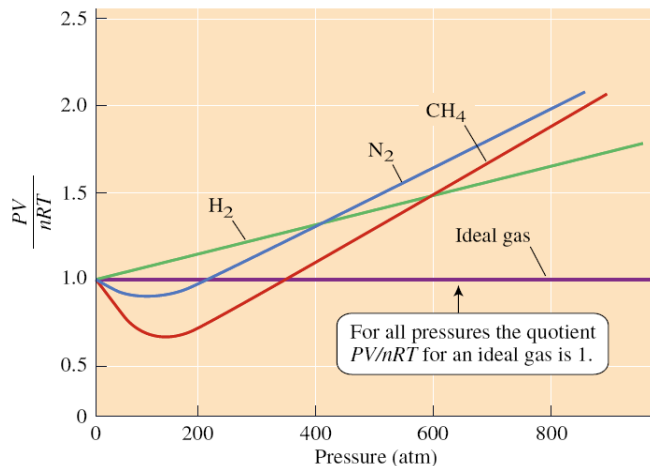

Figure 10.X. A plot of PV/nRT vs. pressure.

All three of the gases shown in Figure 10.x deviate from ideal behavior at high pressures.

Two types of deviations occur from ideal behavior.

1. Deviations due to gas volume.

At high pressures the concentration of the gas in a container is very high and as a result, molecules on average are closer together than they are at lower pressures. At these high pressures the gas molecules begin to occupy a significant amount of the container volume, and thus *the predicted volume occupied by the gas is less than the actual (container) volume*. Because the volume occupied by the gas is less than the container volume, the correction is subtracted from the container volume.

The amount of volume occupied up by the gas molecules depends on the amount of gas present (n), and a constant (b) that represents how large the gas molecules are. Therefore, under non-ideal conditions,

$$V = V_{\text{container}} - nb$$

2. Deviations due to molecular interactions.

Under ideal condition, gas molecules have perfectly elastic conditions. When the temperature decreases, however, gas molecules can interact for a short time after they collide. When this happens, there are fewer effective particles in the container (some molecules form small clusters, decreasing the number of particle-wall collisions) and these molecular interactions decrease the force with which molecules collide with the container walls. Thus, *the predicted pressure of the gas is greater than the actual (measured) pressure*. Because the predicted pressure is greater than measured, the pressure correction is added to the measured pressure.

The strength of these molecular interactions depend greatly on the number of collisions and therefore depend on the amount of gas present (n) and the volume (V) of the container. Gases differ in these interactions, and this is reflected in a constant, a , which is specific to a given gas at a particular temperature. Under non-ideal conditions,

$$P = P_{\text{measured}} + \frac{n^2 a}{V_{\text{container}}^2}$$

These two deviations from ideal behavior are combined into a separate, more sophisticated gas law, the **van der Waals equation**, and Table 10.7 shows some constants for common gases.

$$\left(P_{\text{measured}} + \frac{n^2 a}{V_{\text{measured}}^2} \right) (V - nb) = nRT \quad (10.x)$$

Table 10.7 van der Waals constants

Gas	a (L ² ·atm/mol ²)	b (L/mol)
H ₂	0.244	0.0266
He	0.034	0.0237
N ₂	1.39	0.0391
NH ₃	4.17	0.0371
CO ₂	3.59	0.0427
CH ₄	2.25	0.0428

Notice that the values of “ b ” roughly increase with increasing size of the gas molecules. The values of “ a ” are related to the tendency of molecules of a given species to interact.

EXAMPLE PROBLEM: Non-ideal Gases

A 10.7 mol sample of ammonia gas is maintained in a 0.550 L container at 297 K. Calculate the pressure of the gas using both the ideal gas law and the van der Waals equation (van der Waals constants are in Table 10.7).

SOLUTION:

First use the ideal gas law to calculate the pressure in the flask.

$$P = \frac{nRT}{V} = \frac{(10.7 \text{ mol})(0.082057 \text{ L}\cdot\text{atm}/\text{K}\cdot\text{mol})(297 \text{ K})}{0.550 \text{ L}} = 474 \text{ atm}$$

Compare this pressure to that calculated using the van der Waals equation.

$$\left(P_{\text{measured}} + \frac{n^2 a}{V_{\text{measured}}^2} \right) (V - nb) = nRT$$

$$\left[P_{\text{measured}} + \frac{(10.7 \text{ mol})^2 (4.17 \text{ L}^2 \cdot \text{atm}/\text{mol}^2)}{(0.550 \text{ L})^2} \right] [0.550 \text{ L} - (10.7 \text{ mol})(0.0371 \text{ L}/\text{mol})] = (10.7 \text{ mol})(0.082057 \text{ L}\cdot\text{atm}/\text{K}\cdot\text{mol})(297 \text{ K})$$

$$P_{\text{measured}} = 126 \text{ atm}$$

The actual pressure in the container is much less than that calculated using the ideal gas law.



OWL Example Problems
10.30 Non-ideal Gases

Chapter Review

OWL Summary Assignments
10.XX Chapter Review
10.XX Challenge Problems

Key Equations

$$P_1 \times V_1 = P_2 \times V_2 \quad (10.x)$$

$$\frac{V_1}{T_1} = \frac{V_2}{T_2} \quad (10.x)$$

$$\frac{V_1}{n_1} = \frac{V_2}{n_2} \quad (10.x)$$

$$PV = nRT \quad (10.x)$$

$$\frac{P_1 V_1}{n_1 T_1} = \frac{P_2 V_2}{n_2 T_2} \quad (10.x)$$

$$M = \frac{dRT}{P} \quad (10.x)$$

$$P_{\text{total}} = P_A + P_B + P_C \quad (10.x)$$

$$\frac{P_A}{P_{\text{total}}} = \frac{n_A}{n_{\text{total}}} \quad (10.x)$$

$$P_A = P_{\text{total}} \cdot \chi_A \quad (10.x)$$

$$\chi_A + \chi_B + \chi_C = 1 \quad (10.x)$$

$$\frac{\text{Rate}_1}{\text{Rate}_2} = \sqrt{\frac{M_2}{M_1}} \quad (10.x)$$

$$v_{\text{rms}} = \sqrt{v^2} = \sqrt{\frac{3RT}{M}} \quad (10.x)$$

$$\overline{\text{KE}} = \frac{1}{2}m\overline{v^2} = \frac{3}{2}RT \quad (10.x)$$

$$\left(P_{\text{measured}} + \frac{n^2a}{V_{\text{measured}}^2} \right) (V - nb) = nRT \quad (10.x)$$

Key Terms

10.2 Historical Gas Laws

Boyle's law
Charles's law
Avogadro's law

10.3 The Ideal and Combined Gas Laws

ideal gas law
ideal gas
combined gas law

10.4 Dalton's Law of Partial Pressures

Dalton's Law of Partial Pressures
mole fraction

10.6 Kinetic Molecular Theory

kinetic molecular theory
Boltzmann distribution
root mean square (rms) speed
diffusion
effusion

10.7 Non-Ideal Gases

van der Waals equation